

# Scaffolding

Code of Practice

2021

**WHSQ**

**Workplace Health and Safety Queensland**  
worksafe.qld.gov.au



This Queensland code of practice has been approved by the Minister for Education and Industrial Relations under section 274 of the *Work Health and Safety Act 2011*.

This code commenced on 1 July 2021 with the exception of section 2.7.1.1 of the code which has a delayed commencement. Section 2.7.1.1 sets out that where there is a change in direction between landings, any difference in step height from the scaffold stair to an access or egress point should be minimised so that it is no more than 300mm. Section [2.7.1.1](#) applies to stand-alone scaffolding where erection commences 12 months after 1 July 2021.

PN12684

**ISBN Creative Commons**

This copyright work is licensed under a Creative Commons Attribution-Noncommercial 4.0 International licence. To view a copy of this licence, visit [creativecommons.org/licenses](https://creativecommons.org/licenses). In essence, you are free to copy, communicate and adapt the work for non-commercial purposes, as long as you attribute the work to Safe Work Australia and abide by the other licence terms.

# Contents

- Foreword.....6**
- Scope and application .....6**
- 1. Introduction .....7**
  - 1.1 What is scaffolding?.....7
  - 1.2 What is construction work? .....7
  - 1.3 Who has health and safety duties in relation to scaffolding work?.....7
  - 1.4 What is involved in managing risks associated with scaffolding work?.....8
    - 1.4.1 Consulting workers.....9
    - 1.4.2 Consulting, cooperating and coordinating activities with other duty holders .....9
  - 1.5 Information, training, instruction and supervision .....10
    - 1.5.1 High risk work licences.....11
    - 1.5.2 Competency .....11
- 2. Planning and design .....12**
  - 2.1 Planning construction activities.....12
    - 2.1.1 WHS management plans .....12
    - 2.1.2 Safe work method statements.....12
    - 2.1.3 Scaffold plans.....13
  - 2.2 Design .....13
  - 2.3 Foundations .....16
    - 2.3.1 Ground conditions .....16
    - 2.3.2 Loadings.....16
    - 2.3.3 Soleboards and baseplates.....19
  - 2.4 Stability .....20
    - 2.4.1 Tying .....20
  - 2.5 Perimeter containment screening .....21
  - 2.6 Working platforms.....22
  - 2.7 The work environment .....24
    - 2.7.1 Access and egress.....24
    - 2.7.2 Lighting .....26
    - 2.7.3 Maintaining a safe work environment.....26
- 3. Hazards .....27**
  - 3.1 Working near energised overhead electric lines .....27
  - 3.2 Mobile plant and traffic.....29
  - 3.3 Fixed plant.....29
  - 3.4 Mixing scaffold components .....29
  - 3.5 Falls from height .....30
    - 3.5.1 Risk of a fall at any height .....30
    - 3.5.2 Risk of a fall when erecting scaffold .....31
    - 3.5.3 Risk of a fall when dismantling scaffold.....31
    - 3.5.4 Fall arresting platforms.....31
    - 3.5.5 Edge protection .....32
    - 3.5.6 Fall-arrest systems.....32
  - 3.6 Falling objects.....33
    - 3.6.1 Preventing objects from falling .....34
    - 3.6.2 Gaps .....34
  - 3.7 Scaffold collapse.....35

3.8 Unauthorised access, use or alteration.....	35
3.9 Scaffold quality .....	35
3.10 Ground conditions.....	36
3.11 Hazardous manual tasks .....	36
3.11.1 Examples of design controls .....	36
3.11.2 Examples of administrative controls.....	37
3.12 Fire and explosion .....	37
<b>4. Erecting, altering or dismantling scaffold.....</b>	<b>38</b>
4.1 Safe erection of scaffold .....	38
4.2 Scaffold alteration .....	39
4.3 Safe dismantling of scaffold .....	39
<b>5. Types of scaffold.....</b>	<b>40</b>
5.1 Independent scaffold .....	40
5.1.1 Birdcage scaffold.....	40
5.1.2 Tower scaffold.....	41
5.1.3 Mobile scaffold .....	41
5.1.4 Hung scaffold .....	42
5.2 Single pole scaffold.....	43
5.3 Suspended (swing-stage) scaffold.....	43
5.3.1 Design issues.....	44
5.3.2 Counterweight calculation .....	44
5.3.3 Method of fixing needles .....	44
5.3.4 Suspension systems .....	45
5.3.5 Scaffold hoists.....	45
5.3.6 Cradles.....	45
5.3.7 Trolleys.....	46
5.3.8 Fall-arrest and travel restraint harness systems.....	46
5.4 Complex scaffolds .....	46
5.4.1 Cantilever scaffold.....	46
5.4.2 Hanging bracket scaffold.....	47
5.4.3 Spur scaffold .....	47
5.5 Scaffolding for demolition work.....	47
<b>6. Inspection and maintenance procedures.....</b>	<b>49</b>
6.1 Frequency of inspection of scaffold .....	49
6.2 Structural inspection of scaffolding components.....	49
6.3 Hand over inspections .....	50
<b>Appendix 1: Dictionary .....</b>	<b>51</b>
<b>Appendix 2: Inspection checklist.....</b>	<b>55</b>
<b>Appendix 3: Published technical standards .....</b>	<b>57</b>
<b>Appendix 4: Scaffold handover certificate – scaffold over four metres.....</b>	<b>58</b>
<b>Appendix 5: Compliance pack for suspended (swing-stage) scaffolds .....</b>	<b>59</b>
Swing-stage advice.....	61
A5.1 Equipment supply advice .....	61
A5.2 Scaffold environment advice.....	62
A5.3 Installation design advice.....	62
A5.4 Scaffold erection advice.....	63
A5.5 Electrical installation advice .....	64
A5.6 Scaffold operation advice.....	65
A5.7 Boatswain’s chair operation advice.....	66
PCBU checklists .....	67

A5.8 Swing-stage scaffold supplier checklist .....	67
A5.9 Swing-stage scaffold principal contractor / body corporate checklist .....	67
A5.10 Swing-stage scaffold erection and installation checklist .....	68
A5.11 Swing-stage scaffold electrical installation checklist .....	68
A5.12 Swing-stage scaffold handover checklist .....	69
A5.13 Swing-stage scaffold and boatswain's chair operation checklist.....	69
A5.14 Unattended swing-stage scaffold checklist .....	70
A5.15 Inspection, servicing and maintenance checklist .....	70
Verification forms .....	71
Principal contractor or building owner swing-stage statement .....	72
Competent person benchmarks for swing-stage set-up verification .....	73
Swing-stage suspension system verification statement .....	75

# Foreword

This *Scaffolding Code of Practice* is an approved code of practice under section 274 of the *Work Health and Safety Act 2011* (the WHS Act).

An approved code of practice is a practical guide to achieving the standards of health, safety and welfare required under the WHS Act and the Work Health and Safety Regulation 2011 (the WHS Regulation).

**Under section 26A of the WHS Act duty holders must comply with an approved code of practice or follow another method, such as a technical or industry standard, if it provides an equivalent or higher standard of work health and safety than the standard required in this code.**

A code of practice applies to anyone who has a duty of care in the circumstances described in the code. In most cases, following an approved code of practice would achieve compliance with the health and safety duties in the WHS Act, in relation to the subject matter of the code. Like regulations, codes of practice deal with particular issues and do not cover all hazards or risks which may arise. The health and safety duties require duty holders to consider all risks associated with work, not only those for which regulations and codes of practice exist.

Codes of practice are admissible in court proceedings under the WHS Act and WHS Regulation. Courts may regard a code of practice as evidence of what is known about a hazard, risk or control and may rely on the code in determining what is reasonably practicable in the circumstances to which the code relates.

An inspector may refer to an approved code of practice when issuing an improvement or prohibition notice. This may include issuing an improvement notice for failure to comply with a code of practice where equivalent or higher standards of work health and safety have not been demonstrated.

## Scope and application

This code provides practical guidance to persons conducting a business or undertaking on how to comply with their health and safety duties relating to scaffolds, scaffolding and scaffolding work.

### How to use this code of practice

In providing guidance, the word 'should' is used in this code to indicate a recommended course of action, while 'may' is used to indicate an optional course of action.

This code also includes various references to provisions of the WHS Act and WHS Regulation which set out the legal requirements. These references are not exhaustive. The words 'must', 'requires' or 'mandatory' indicate that a legal requirement exists and must be complied with.

# 1. Introduction

## 1.1 What is scaffolding?

Scaffolding means:

- the individual components of plant (e.g. tubes, couplers or frames and materials that when assembled form a scaffold)
- a temporary structure specifically erected to support access or working platforms.

Scaffolding work means erecting, altering or dismantling a temporary structure that is or has been erected to support a platform and from which a person or object could fall more than four metres from the platform or the structure.

## 1.2 What is construction work?

**WHS Regulation section 289:** Construction work means any work carried out in connection with the construction, alteration, conversion, fitting-out, commissioning, renovation, repair, maintenance, refurbishment, demolition, decommissioning or dismantling of a structure.

Construction work includes:

- installation or testing carried out in connection with an activity referred to in the definition
- the removal from the workplace of any product or waste resulting from demolition
- the prefabrication or testing of elements at a place specifically established for the construction work, for use in construction work
- the assembly of prefabricated elements to form a structure, or the disassembly of prefabricated elements forming part of a structure
- the installation, testing or maintenance of an essential service for a structure
- work connected with an excavation
- work connected with any preparatory work or site preparation including landscaping as part of site preparation carried out in connection with an activity referred to in the definition above
- an activity referred to in the definition carried out on, under or near water including work on buoys and obstructions to navigation.

In addition, scaffolding work may include construction work that is defined as high risk construction work in the WHS Regulation for which a safe work method statement (SWMS) must be prepared before the work starts (see Section 2.1.2 of this code for more information on SWMS requirements).

## 1.3 Who has health and safety duties in relation to scaffolding work?

A **person conducting a business or undertaking** (PCBU) has the primary duty to ensure, as far as reasonably practicable, workers and other people are not exposed to health and safety risks arising from the business or undertaking.

This duty requires the person to manage risks by eliminating health and safety risks so far as is reasonably practicable, and if it is not reasonably practicable to eliminate the risks, by minimising those risks so far as is reasonably practicable.

It also includes ensuring, so far as is reasonably practicable the:

- design, provision and maintenance of safe scaffolding plant and structures
- safe erection, alteration, dismantling and use of scaffolding
- safe use, handling, storage and transport of scaffolding plant.

The WHS Regulation includes specific duties for a PCBU with management or control of a construction workplace, plant, powered mobile plant and plant that lifts or suspends loads.

**Designers, manufacturers, suppliers and importers** of plant or structures, including temporary structures, must ensure, so far as is reasonably practicable, the plant or structure is without risks to health and safety. This duty includes providing information to manufacturers so that plant can be manufactured and erected to the design specifications. Designers must give the person who commissioned the design of the temporary structure a written safety report.

**People installing, constructing or commissioning** plant or structures must ensure, so far as is reasonably practicable, all workplace activity relating to the plant or structure including its installation, use, decommissioning or dismantling is without risks to health or safety.

**Officers**, such as company directors, have a duty to exercise due diligence to ensure that the business or undertaking complies with the WHS Act and WHS Regulation. This includes taking reasonable steps to ensure that the business or undertaking has and uses appropriate resources and processes to provide and maintain a safe work environment.

**Workers and other people at the workplace** must take reasonable care for their own health and safety, cooperate with reasonable policies, procedures and instructions and not adversely affect other people's health and safety.

## 1.4 What is involved in managing risks associated with scaffolding work?

**WHS Regulation section 297:** A PCBU must manage risks associated with the carrying out of construction work.

**WHS Regulation section 34-38:** To manage risk, a PCBU must:

- identify reasonably foreseeable hazards that could give rise to risks to health and safety
- eliminate risks to health and safety so far as is reasonably practicable
- if it is not reasonably practicable to eliminate risks to health and safety—minimise those risks so far as is reasonably practicable by implementing risk control measures according to the hierarchy of control in WHS Regulation 36
- ensure the control measure is, and is maintained so that it remains, effective
- review and as necessary revise control measures implemented to maintain, so far as is reasonably practicable, a work environment that is without risks to health or safety.

To properly manage risks, a person must:

- identify hazards – find out what causes the harm
- assess risks that may result because of the hazards – understand the nature of the harm that could be caused by the hazard, how serious the harm could be and the likelihood of it happening
- decide on control measures to prevent, or minimise the level of the risks and implement control measures
- monitor and review the effectiveness of the measures.



Control measures to manage the risk of falls (see WHS Regulations 78 and 79) must be implemented in an order of priority and before work commences. The following example illustrates the order of priority where there is a risk a person could fall.

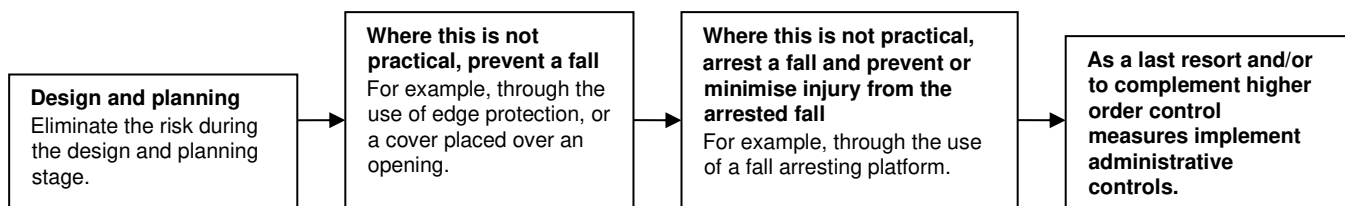

Guidance on the general risk management process is available in the How to manage work health and safety risks Code of Practice.

Hazards associated with work involving the erection, alteration and/or dismantling of scaffolding are discussed in Sections 3 and 4 of this code.

### 1.4.1 Consulting workers

**WHS Act section 47(1):** The PCBU must, so far as is reasonably practicable, consult with workers who carry out work for the business or undertaking who are, or are likely to be, directly affected by a matter relating to work health or safety.

**WHS Act section 48(2):** If the workers are represented by a health and safety representative, the consultation must involve that representative.

Consultation involves sharing of information, giving workers a reasonable opportunity to express views and taking those views into account before making decisions on health and safety matters.

Consultation with workers and their health and safety representatives is required at each step of the risk management process. In many cases decisions about construction work and projects are made before engaging workers so it may not always be possible to consult with workers in these early stages. However, it is important to consult with workers as scaffolding work progresses. By drawing on the experience, knowledge and ideas of workers, a PCBU is more likely to identify hazards and choose effective control measures.

A PCBU should encourage workers to report hazards and health and safety problems immediately so the risks can be managed before an incident occurs and a PCBU must consult workers when proposing any changes to the work that may affect their health and safety.

### 1.4.2 Consulting, cooperating and coordinating activities with other duty holders

**WHS Act section 46:** If more than one person has a duty in relation to the same matter, each person with the duty must, so far as is reasonably practicable, consult, cooperate and coordinate activities with all other persons who have a duty in relation to the same matter.

Sometimes a PCBU may share responsibility for a health and safety matter with other business operators who are involved in the same activities or who share the same workplace. In these situations, the PCBUs must exchange information to find out who is doing what and work together in a cooperative and coordinated way so that all risks are eliminated or minimised as far as reasonably practicable.

Further guidance is available in the *Work health and safety consultation, cooperation and coordination Code of Practice*.

## 1.5 Information, training, instruction and supervision

**WHS Act section 19(3)(f):** A PCBU must ensure, so far as is reasonably practicable, the provision of any information, training, instruction or supervision that is necessary to protect all persons from risks to their health and safety arising from work carried out as part of the conduct of the business or undertaking.

**WHS Regulation section 39(2) and (3):** A PCBU must ensure that information, training and instruction provided to a worker is suitable and adequate having regard to the:

- nature of the work carried out by the worker
- nature of the risks associated with the work at the time of the information, training and instruction
- control measures implemented.

The person must ensure, so far as is reasonably practicable, that the information, training and instruction provided under this regulation is provided in a way that is readily understandable by any person to whom it is provided.

**WHS Regulation section 317(1):** A PCBU must not direct or allow a worker to carry out construction work unless the worker has successfully completed general construction induction training and if the worker completed the training more than two years previously—the worker has carried out construction work in the preceding two years.

All persons who may be exposed to work health and safety risks resulting from scaffolding work must be provided with information and training that is specific to the scaffold that is being used.

Such training and information should include details of:

- the scaffold, tasks, activities and components
- any scaffold plan
- the way the manufacturer or designer of the scaffold intended the system to be erected, installed, used, moved, altered or dismantled
- specific training and information required to undertake or participate in specific tasks or activities
- control measures to minimise exposure to the risks, correct use of controls, and how to ensure they are kept in full working order
- safe working procedures, including the use of mechanical aids and devices, where appropriate
- how to use and maintain equipment, including any specific conditions and prohibitions on the use of equipment – reference should be made to operating manuals
- any special safety information needed such as safety precautions for working under certain conditions
- personal protective equipment required, including instruction in fitting, use, cleaning, maintaining and storing this equipment
- how accidents have occurred in the past involving the same work process or processes.

Persons involved in scaffolding work should also be provided with more general work health and safety information and training including:

- the effects of noise on their hearing and health
- Queensland's work health and safety legislation, including relevant parts of this code of practice
- the workplace's health and safety policies, and relevant procedures and SWMS
- the risk management process

- inspection and maintenance programs in place at the workplace
- how to access information such as manufacturer's instructions about hazards
- emergency procedures, including persons with specific emergency roles and responsibilities.

### 1.5.1 High risk work licences

**WHS Regulation section 81:** A person must not carry out a class of high risk work unless the person holds a high risk work licence for that class of high risk work, except as provided in section 82 WHS Regulation.

In performing scaffolding work where a person or thing may fall more than four metres from the scaffold, a scaffolder must hold a basic, intermediate or advanced high risk work licence as specified under Schedule 3 of the WHS Regulation. Only a person who holds a qualification set out in Schedule 4 of the WHS Regulation may apply for a high risk work licence.

A PCBU must not direct or allow a worker to carry out high risk work unless the person sees written evidence that the worker has the relevant high risk work licence. The PCBU must keep a record of this written evidence.

A high risk work licence expires five years after the date it is granted.

### 1.5.2 Competency

A person is not required to hold a high risk work licence for scaffolding work if a person or thing may fall four metres or less from the scaffold. However, PCBUs and principal contractors still have a general duty to ensure the workplace health and safety of themselves, workers and other persons. This includes ensuring any person performing scaffolding work is competent. The person should receive information, instruction, training and supervision in the safe erection, dismantling, maintenance and alteration of the scaffold.

'Competent person' is defined in the dictionary in Appendix 1.

### 1.5.3 Trainees

**WHS Regulation section 82(1):** A person who carries out high risk work is not required to be licensed if the work is carried out:

- in the course of training towards a certification in order to be licensed to carry out the high risk work
- under the supervision of a person who is licensed to carry out the high risk work.

A person is a trainee if they are enrolled in an applicable high risk work course and under direct supervision from a suitably licensed person. Trainees must be trained to the relevant unit of competency; this means the trainee must receive training involving both theory and practical demonstration. The training must be provided by a registered training organisation with the assessment administered by a Workplace Health and Safety Queensland accredited high risk work assessor.

A PCBU must ensure that a person supervising the work of a trainee, provides direct supervision. Direct supervision means the oversight of the trainee's work for the purposes of directing, demonstrating, monitoring and checking the work in a way appropriate to the trainee's level of competency and ensuring a capacity to respond in an emergency situation.

## 2. Planning and design

The following section provides general advice regarding the safe construction of basic types of scaffolds. Further information about particular types of scaffold can be found in Section 5 *Types of scaffold*.

### 2.1 Planning construction activities

Planning before scaffolding work starts can help eliminate many of the associated health and safety risks. An effective plan will help identify ways to protect persons who are:

- erecting, dismantling, maintaining and altering the scaffold
- using the scaffold
- near the scaffold (e.g. other workers and members of the public).

Scaffold plans, WHS management plans, and SWMS for high risk construction activities, are tools that can be used to safely plan and manage work on scaffolds and help in meeting health and safety duties under the WHS Act.

#### 2.1.1 WHS management plans

**WHS Regulation section 309:** A principal contractor for a construction project<sup>1</sup> must prepare a written WHS management plan for the workplace before work on the project commences.

The plan should be easy to understand and must be readily available for the length of the project. The principal contractor cannot allow work to start unless the plan has been discussed with, or a copy given, to all relevant people. The plan must include:

- the names, positions and health and safety responsibilities of all persons at the workplace whose positions or roles involve specific health and safety responsibilities in connection with the project
- the arrangements in place, between any PCBUs at the workplace where the construction project is being undertaken, for consultation, cooperation and the coordination of activities in relation to compliance with their duties under the WHS Act and WHS Regulation
- the arrangements in place for managing any work health and safety incidents
- any site-specific health and safety rules, and the arrangements for ensuring that all persons at the workplace are informed of those rules
- the arrangements for the collection and any assessment, monitoring and review of SWMS at the workplace.

The principal contractor for a construction project must review and, as necessary, revise the WHS management plan if there are changes in how risks will be managed, as well as ensuring that all relevant people are informed of the revisions.

#### 2.1.2 Safe work method statements

**WHS Regulation section 299:** A SWMS must be prepared for high risk construction work before work starts.

---

<sup>1</sup> A construction project is a project that involves construction work where the cost of the construction work is \$250,000 or more (section 292 WHS Regulation).

Work on scaffolds is considered high risk construction work where it involves the risk of a person falling more than two metres. A range of other activities that are considered high risk construction work are listed under section 291 of the WHS Regulation.

The SWMS must:

- identify the type of high risk construction work being done
- specify the health and safety hazards and risks arising from the work
- describe the measures that will be implemented to control the risks
- describe how the control measures will be implemented, monitored and reviewed.

A SWMS must, so far as is reasonably practicable, be developed in consultation with workers and their representatives who are carrying out the high risk work.

### 2.1.3 Scaffold plans

A scaffold plan is to be prepared for scaffolding work above four metres (measured from the top working platform (TWP) to the ground) and provided by the PCBU doing the scaffolding work. All scaffolds should be built in accordance with the relevant Australian Standard (*AS/NZS 1576 Scaffolding*). What is constructed on site should reflect what is in the scaffold plan.

To develop an effective and useful scaffold plan consult with:

- the scaffold designer (e.g. to discuss the design loads and the capability of the structure to support any additional loadings)
- the builder or principal contractor (e.g. to assess the location of underground drains or pits). The work should be planned so as to avoid excavating service trenches under, through or adjacent to scaffolds
- workers, workplace health and safety committees, and workplace health and safety representatives, regarding erecting, dismantling, maintaining and altering the scaffold.

The scaffold plan is to include a site layout plan and sufficient detail to adequately describe the scaffold to be erected and may include section and elevation details. It is to be made available for inspection at the worksite. The scaffold plan should address the following issues:

- basis of design
- foundations (including ground conditions, slope and loadings)
- supporting structure
- access and egress
- tying
- bracing
- type of scaffold
- edge protection
- number of plank levels
- number of working levels (Note: the number of working levels often varies to the number of plank levels erected on the scaffold. This information should be clearly communicated at handover and to the end user. Using more than the designed working levels at once will exceed the nominated leg loads and may overload the scaffold).

## 2.2 Design

**WHS Regulation section 243:** The design of an item of plant stated in Schedule 5, part 1 WHS Regulation must be registered. Prefabricated scaffolding must be design registered.

Prefabricated scaffolding is an integrated system of prefabricated components manufactured in such a way that the geometry of assembled scaffolds is pre-determined and can include modular, tower, cantilever, hung and suspended scaffolds.

The person with management or control of the prefabricated scaffolding must ensure the design registration number is kept where it is readily accessible.

**WHS Act section 22:** A person (the designer) who conducts a business or undertaking that designs plant or a structure that is to be used, or could reasonably be expected to be used, as, or at, a workplace must ensure, so far as is reasonably practicable, that the plant or structure is designed to be without risks to the health and safety of persons who:

- use the plant or structure at a workplace for a purpose for which it was designed
- store the plant
- construct the structure
- carry out any reasonably foreseeable activity at a workplace in relation to the manufacture, assembly or use of the plant or structure for a purpose for which it was designed, or the proper storage, decommissioning, dismantling or disposal of the plant or structure
- are at or in the vicinity of a workplace and who are exposed to the plant or structure at the workplace or whose health or safety may be affected by one of the above uses or activities.

The designer must:

- carry out, or arrange the carrying out of, any calculations, analysis, testing or examination that may be necessary to ensure, so far as is reasonably practicable, that the plant or structure is designed to be without risks to the health and safety of persons
- give adequate information to each person who is provided with the design for the purpose of giving effect to it
- on request, so far as is reasonably practicable, give current relevant information to a person using the plant or structure for a purpose for which it was designed or when carrying out a reasonably foreseeable activity using the plant.

**WHS Regulation section 294:** A PCBU that commissions construction work (the client) in relation to a structure must, so far as is reasonably practicable, consult with the designer of the whole or any part of the structure about how to ensure that risks to health and safety arising from the design during construction are eliminated or minimised so far as is reasonably practicable.

Consultation must include giving the designer any information that the person who commissions the construction work has in relation to the hazards and risks at the workplace where the construction work is to be carried out.

The design of the structural members and components of a scaffold should comply with the *AS/NZS 1576* series of documents.

The design of the scaffold should take into account the:

- strength, stability and rigidity of the supporting structure
- intended use and application of the scaffold
- safety of persons engaged in the erection, alteration and dismantling of the scaffold
- safety of persons using the scaffold
- safety of persons in the vicinity of the scaffold.

Design verification is a process involving the review of design documentation (scaffold plans) to determine if the design complies with the technical design standard specified for particular plant or structures.

An 'engineer' (as defined in Appendix 1), such as a suitably qualified engineer experienced in the structural design of scaffolds, is usually responsible for verifying the information required to document the safe design and certification of the complete scaffold structure. The engineer may be employed directly by either the manufacturer, supplier, erector, or be acting as an independent consultant.

The following table indicates when an engineer should design verify and inspect various scaffolds.

Type of scaffold	Design verification (1), (3), (4)	Initial inspection (2)
Minor scaffold (less than 2 m TWP) or modular scaffold (less than 4 m TWP)	Supplier or competent person	Competent person
Modular scaffold 4 m to maximum height (5) (6)	Supplier or competent person	Scaffolder
Modular scaffold (with cladding) above 4 m (5) (6)	Supplier or engineer	Scaffolder
Modular scaffold outside of standard documented manufacturer's parameters (7)	Engineer	Scaffolder
Tube and coupler scaffold greater than 33 m TWP or outside of scope of AS/NZS 1576.6	Engineer	Scaffolder
Cantilevered steel beams, trusses or ladder beams (8)	Engineer	Scaffolder
Cantilevered or spurred scaffold (greater than 6 m high)	Engineer	Scaffolder
Bridging beams, truss or ladder beams (greater than 4.8m span or 6m of scaffold above)	Engineer	Scaffolder
Hung or drop scaffolds (8)	Engineer	Scaffolder
Independent free standing or guyed scaffold towers – greater than 4 m TWP (including aluminium static or mobile tower more than 9 m TWP)	Engineer	Scaffolder
Crane lifted scaffold (9)	Engineer	Scaffolder and Crane Dogger
Access birdcages (10) (with cladding or more than 20 m TWP)	Engineer	Scaffolder
Mobile scaffold – greater than 4 m TWP (excluding standard aluminium mobile scaffolds)	Engineer	Scaffolder
Stair tower – independent or attached (more than 20 m high)	Engineer	Scaffolder
Gantry or overhead protection structures	Engineer	Scaffolder
Loading bays (greater than 9 m TWP or 2T) (11)	Engineer	Engineer
Suspended scaffold (swing-stage and supports)	Engineer	Engineer
Perimeter demolition scaffold (more than 9 m high)	Engineer	Engineer
Public access structures (requiring Building Code of Australia compliance)	Engineer	Engineer

**Table 1** Planning construction activities (design and inspection table)

Notes:

1. Design documents can be produced by a competent person provided they are based on tables, charts, brochures or information which has previously been verified for compliance with AS/NZS 1576 by a suitably qualified person such as a Registered Professional Engineer of Queensland (RPEQ) engineer experienced in the design of temporary works.
2. Initial inspections prior to use for compliance with all design documents to be carried out by a suitably qualified scaffolder unless noted otherwise. Ongoing and 30-day inspections may also be completed by a suitably qualified scaffolder or experienced engineer.
3. Minor non-structural changes to scaffold such as smaller bay size substitution, hop up moves, stair location etc. do not require additional engineering verification.
4. Scaffolds that require an undocumented structural change should be referred to the designer or engineer for approval and/or inspection.

5. Maximum height refers to a manufacturer's maximum approved height. Different systems will have different approved heights and loading configurations. These details should be included as part of the scaffold documentation.
6. Scaffolds over 30 m with staggered tie patterns on adjacent legs may often require specific engineering design due to the large leg loads and buckling effects of unsupported standards.
7. Complex scaffolds where standards are not continuous from top to bottom (typically some industrial type scaffolds and large civil works) should be certified by an engineer.
8. Due to the complexity or critical nature of a scaffold, the designer may deem it necessary to have engineering inspections.
9. Inspections of crane lifted scaffold should be undertaken by both the scaffolder and the crane dogger to ensure all lifting points and methods are clearly communicated to all parties. The crane crew is not expected to inspect or verify the scaffold but only to be made aware of the designed lifting arrangements. Lifting points and slinging arrangements are to be designed by an engineer.
10. In accordance with *AS/NZS 1576*, some types of equipment that incorporate temporary working platforms may not be considered to be a scaffold. These types of equipment may include formwork support systems erected primarily for the support of concrete and should be designed and used in accordance with *AS 3610* and the Formwork Code of Practice.
11. All loading/landing bays that exceed the duty rating of the scaffold need to be design verified by an engineer.

## 2.3 Foundations

Scaffold foundations should be able to carry and distribute all the weight of the scaffold, including any extra loads (e.g. perimeter containment screens, placed on the scaffold).

Obtain advice from an engineer before erecting scaffolds on verandas, suspended flooring systems, compacted soil, parapets, awnings and similar structures.

Consideration should be given to the following when designing the foundation of the scaffold.

### 2.3.1 Ground conditions

Water and nearby excavations may lead to soil subsidence and scaffold collapse. Any likely watercourse, such as a recently filled trench, which has the potential to create a wash out under the scaffold base, should be diverted away from the scaffold.

Soft ground can be disguised by a relatively thin crust on the surface where the ground has dried out, however, under the surface crust the ground is still soft. The hard crust can give the false perception that the ground has adequate bearing capacity, but when the load on the scaffold increases, the scaffold can suddenly punch through the crust causing the scaffold to collapse.

The principal contractor or PCBU commissioning the scaffold is responsible for preparing the ground and providing information and advice in writing to the scaffolder on its bearing capacity. Before erection begins, the principal contractor or PCBU should know what loadings will be imposed on the ground by the scaffold, ensure ground conditions are stable and inform scaffold erectors of any factors which may affect ground stability. If there are any doubts or obvious signs that the ground may be suspect (i.e. soft ground, fill, underground services, etc.), the principal contractor or PCBU may need to engage the services of a competent person, such as a geotechnical engineer, to assess the ground and specify suitable control measures.

### 2.3.2 Loadings

A scaffold needs to be designed for the most adverse combination of dead, live and environmental loads that can reasonably be expected during the period that the scaffold is in use.



The dead, live and environmental loads will need to be calculated during the design stage to ensure the supporting structure and the lower standards are capable of supporting the loads. The design of scaffolds and ties should be approved by a competent person or an engineer. Follow the specifications of the manufacturer, designer or supplier for the maximum loads of the scaffold.

Propping may be required where the supporting structure is not capable of bearing the most adverse combination of loads.

### 2.3.2.1 Environmental loads

Consider environmental loads, particularly the effects of wind and rain on the scaffold. For example, environmental loads imposed by wind and rain may be heightened if perimeter containment screening, cladding or signs are attached to the scaffold. The effects of climatic conditions (e.g. electrical storms) on the scaffold should also be considered.

The geographical location of the construction site will have a bearing on the severity of wind on the structure. Wind generally has less effect in built up or hilly areas. *AS/NZS 1170.2 Structural Design Actions - Wind Actions* specifies four different terrain categories that should be taken into consideration by an engineer as well as basic wind speeds for different zones in Australia.

There are three regions for Queensland:

- **Region A4 (normal)** – most of Queensland excluding coastal areas (includes Toowoomba and Mt Isa)
- **Region B (intermediate)** – Queensland coastal areas south of Bundaberg and a narrow band behind region C (includes Brisbane and all of Gold Coast and Sunshine Coast)
- **Region C (tropical cyclones)** – all coastal areas north of, and including, Bundaberg. Region C has the greatest wind speeds.

Procedures for dealing with seasonal high wind events should be prepared for cyclone-prone areas.

Staggering the joints in standards may help control the risk of scaffold collapse from environmental loads. Refer to *AS/NZS 1576.1 Scaffolding – General Requirements* for additional information.



**Figure 1.** 'Tension splices' or 'through bolts' may be required to secure scaffold components together to accommodate environmental loads.

### 2.3.2.2 Dead loads

Dead loads refer to the self-weight of the scaffold structure and components including any working, catch or access platforms, stairways, ladders, screens, sheeting, platform brackets, suspension ropes, secondary ropes, traversing ropes, tie assemblies, scaffolding

hoists or electrical cables. Dead loads should be calculated in accordance with *AS/NZS 1576.1 Scaffolding – General Requirements*.

### 2.3.2.3 Live loads

The live load includes:

- the weight of people
- the weight of materials and debris
- the weight of tools and equipment
- impact forces.

Scaffolds should not be used to support formwork and plant, such as hoist towers and concrete pumping equipment, unless the scaffold is specifically designed for this purpose.

The live loads applied to a working platform should be in accordance with those specified in Table 2.

	<b>Design total load</b> (kg per platform per bay)	<b>Design concentrated load</b> (part of total load – applied in most adverse position within bay) (kg)	<b>Minimum width of platform</b> (mm)
<b>Light duty</b> < 3 metres during housing construction work < 2 metres during other construction work e.g. painting, cleaning, fascia and gutter installation	125 (1.2kN)	100 (1kN)	225 mm
<b>Light duty</b> ≥ 3 metres during housing construction work ≥ 2 metres during other construction work	225 (2.2kN)	120 (1.2kN)	450 mm
<b>Medium duty</b> For example: finishing trades where light materials are stacked on the platform.	450 (4.4kN)	150 (1.5kN)	675 mm (for emergency access platforms minimum 900 mm width)
<b>Heavy duty</b> For example: bricklaying and demolition work (special duty may be required for some demolition).	675 (6.6kN)	200 (2kN)	900 (or 675 mm where additional access is provided by a bay extension platform of not less than 450 mm width)
<b>Loading platforms</b>	Not less than 5kPa with an impact factor of 1.25 allowed for by the designer		Specified by the designer
<b>Special duty</b>	Seek guidance from designer, manufacturer, supplier or engineer but not less than 1kPa in accordance with		Specified by the designer

	AS/NZS 1576.1 Scaffolding – General Requirements	
<b>Ladder access hatches</b>	Rated to match point load of the duty rating of platform	

**Note:** No materials are permitted on platforms 450 mm wide or less. All other scaffolds should have a clear platform width of at least 450 mm.

**Table 2** Requirements for working platforms

### 2.3.3 Soleboards and baseplates

Soleboards and baseplates can be used to evenly distribute the load from the scaffold to the supporting surface (see Figure 2). Both soleboards and baseplates may be required for use on less stable surfaces, such as soil, gravel, fill or other supporting structures.

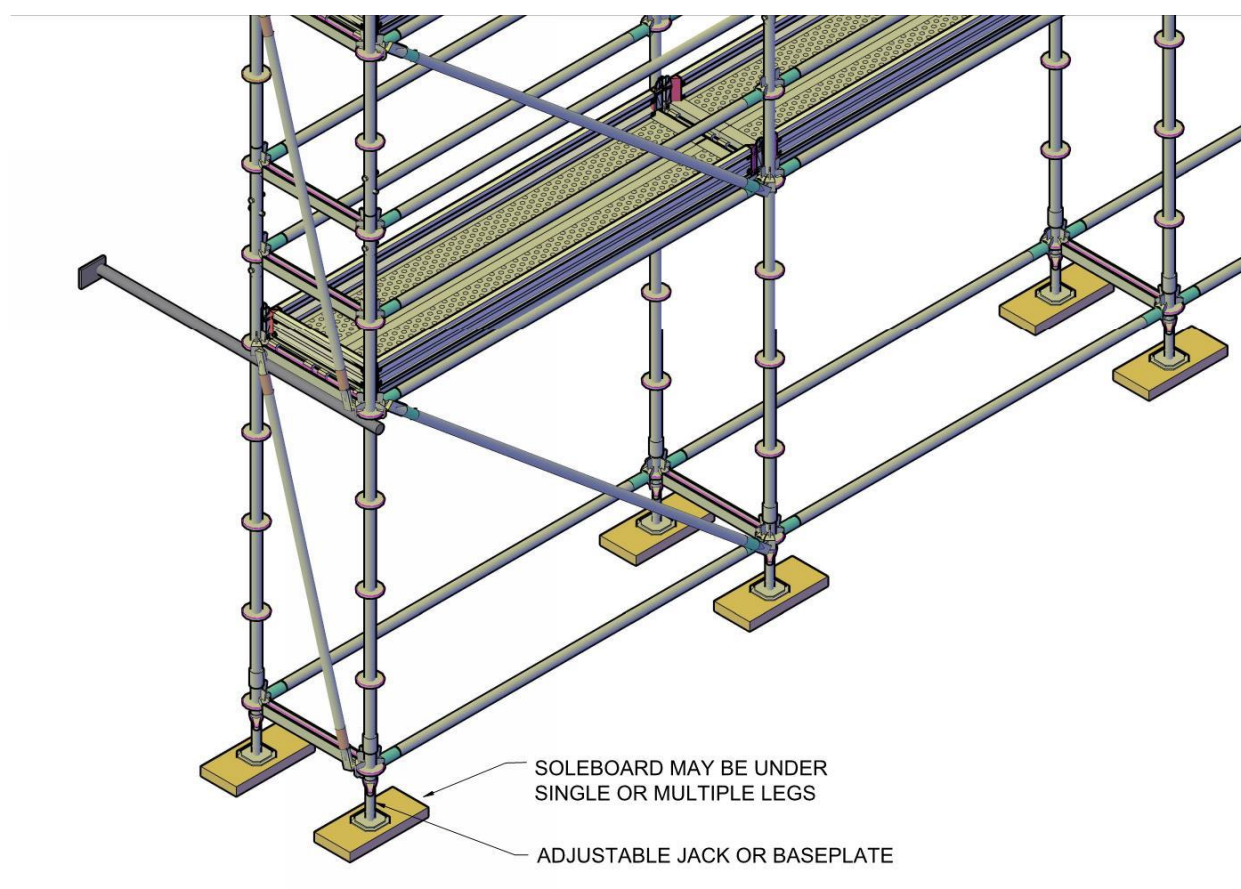

**Figure 2.** Soleboards and baseplates

The size of the soleboard will vary depending on the supporting surface. If in doubt a PCBU may need to consult an engineer to determine the bearing capacity of the ground or other supporting structure, such as a lightweight roof or floor system. To reduce point loading, it may be necessary to install a longer soleboard to support both inner and outer legs or install a beam grillage system to adequately spread the load from the scaffold to the support structure below.

Soleboards are generally not required on firm surfaces such as concrete. If soleboards are required to spread loads over softer ground, they should be 500 mm long, 225 mm wide and 30 mm thick hardwood timber at a minimum, or a substitute material and size certified by the scaffold designer or a competent person. Soleboards should be level and some digging may be required to obtain a level surface.

Adjustable bases can be used on uneven surfaces for modular scaffold systems. No part of the baseplate or adjustable base should protrude over the side of the soleboard to ensure the loads are imposed evenly on the soleboard.

Needles and spurs should be considered where ground conditions are very unstable.

## 2.4 Stability

Scaffold stability may be achieved by:

- tying the scaffold to a supporting structure
- guying to a supporting structure
- increasing the dead load by securely attaching counterweights near the base
- adding bays to increase the base dimension.

### 2.4.1 Tying

Tie methods and spacing need to be in accordance with the instructions of the manufacturer, designer or supplier. All tying information should be available on site and comply with the details on the scaffold plan.

Outlined below are safe work practices and control measures for tying scaffold:

- A tie should be installed when an unclad scaffold reaches three times the minimum base width unless otherwise noted in design documentation. Cladded scaffolds may require ties installed at a lower height.
- Consult with the scaffold designer, manufacturer, supplier or an engineer if it is not practical to position the ties in accordance with the instructions.
- More ties may be required if:
  - the scaffold is cladded (due to increased wind loadings)
  - it is used as a loading platform for materials or equipment
  - attaching lifting appliances or rubbish chutes.
- The principal contractor or a PCBU should have a competent person regularly inspect the existence and effectiveness of scaffold ties to ensure they are not modified or altered by unauthorised persons (e.g. finishing trades who may loosen, relocate or remove ties to obtain access to walls and openings).
- Ties should not obstruct access along the working and access platforms.
- Ties should interconnect with both the inner and outer scaffold standards (unless otherwise specified by an engineer or by the scaffold manufacturer/supplier documentation) to increase the rigidity of the scaffold. Engineering documentation should be site-specific if the proposed arrangement is not covered by a generic design.
- Single leg ties should have a safety coupler on the tie behind the standard. Where tie tubes are connected to the structure via a bracket, a safety coupler should be used at the bracket connection point.
- Consult with the scaffold designer or supplier before attaching additional loads on the scaffold (e.g. signs and perimeter containment screens).
- Cast-in anchors or 'through bolts' (i.e. pass through a wall) are preferred to post-installed anchors for securing scaffold ties because of possible failure due to faulty tensioning or epoxies.
- Post-installed anchors should conform with the following requirements:
  - Only chemical anchors, screw bolts, coil expansion anchors or torque-controlled expansion anchors should be used; drop-in (impact setting) or deformation-controlled expansion anchors should not be used. Caution should be exercised when using screw bolts due to the very tight hole tolerances required. While coil expansion anchors and torque-controlled anchors can tolerate a small variation in hole size, the allowable variation in hole tolerance for a screw bolt will be significantly reduced. If the hole is too large, the grooves cut by the thread will not be deep enough and the screw bolt will not

- achieve adequate pull out resistance; too small and the bolt may not achieve sufficient embedment to provide the required design load.
- An assessment of the substrate to which the anchors are to be installed should be conducted to confirm their suitability for the application. Site documentation should be available to indicate the details and results of the substrate assessment. The assessment should consider, as a minimum:
    - o the required working load limit
    - o the concrete strength at the time of installation
    - o whether the concrete will remain uncracked throughout the service life of the anchors.
  - The working load limit specified by the anchor supplier in the direction of applied load should be greater than or equal to 6 kN for horizontal tie anchors, or three times the maximum calculated applied load for all other anchors.
  - For post-installed anchors, a method for verifying the load capacity and correct installation should be specified in the anchorage design. All post-installed anchors should be installed using a torque wrench set to the appropriate torque, unless the anchor has an inbuilt torque indicator or is installed using a manufacturer's approved installation procedure. Documented verification is to be kept on site, stating the anchor setting torque or installation procedure, date of installation, location of installation, and name of the competent person installing the anchor. Individual proof-testing (100 per cent of design load) of all chemical anchors installed is to be undertaken and documented. Refer to Appendix E of AS/NZS 1576.1 for further information on anchors.
  - Ties to masonry and to substrates other than concrete shall be specified through engineering assessment based on them achieving the performance and reliability for the specific application. Each anchor shall be capable of sustaining all of the imposed cyclic loads without damage to the substrate or reduction in capacity of the anchor.
  - Anchors for securing rakers to a concrete slab should be capable of resisting the combined shear and tensile forces.
  - Anchors conforming to AS 3850.1 Prefabricated concrete elements – General requirements that require component reinforcement should not be used unless correct installation of the reinforcement is confirmed prior to pouring of concrete.

## 2.5 Perimeter containment screening

Perimeter containment screening is used to protect persons from falling objects and should be located inside the standards on working platforms.

Perimeter containment screens must be made of mesh, timber, plywood, metal sheeting or other material suitable for the purpose. The requirements for mesh are summarised in Table 3 (also see Figure 3).

Mesh pattern	Size of mesh openings (max)	Mesh gauge
Square or other rectangle		
- with prescribed lining*	50 mm x 50 mm	2.5 mm
- without prescribed lining*	25 mm x 25 mm	2.5 mm
- without prescribed lining*	25 mm x 50 mm	2.5 mm
Not square or other rectangle		
- with prescribed lining*	50 mm in any direction	2.5 mm
- without prescribed lining*	25 mm in any direction	2.5 mm

\* **prescribed lining** means intact shade cloth, or another intact lining, that when tested, wet or dry, in accordance with method A in AS 2001.2.4 has a mean bursting pressure of at least 1000 kPa.

**Table 3** Summary of requirements for mesh perimeter containment screens

The prescribed lining must be attached to the inside of the mesh and can be attached using non-structural locating product which keeps the lining in place while minimising damage to the lining.

The framework supporting a screen must be able to bear the load of the screen.

Refer to the *AS/NZS 1576* series of documents for additional information on appropriate minimum loads and fixing requirements.

Each of the following gaps must not be over 25 mm:

- (a) the gap, measured horizontally, between screens immediately beside each other
- (b) the gap, measured vertically, between a screen and another screen immediately above it
- (c) the gap, measured vertically or horizontally, between a screen and the framework supporting it.

Containment sheeting should be installed no higher than the upper most tie, unless certified otherwise by an engineer.

Where work is carried out close to pedestrian or vehicular access, scaffolds that are sheeted down to hoarding level can minimise both the risk to the public and the area lost to public access.

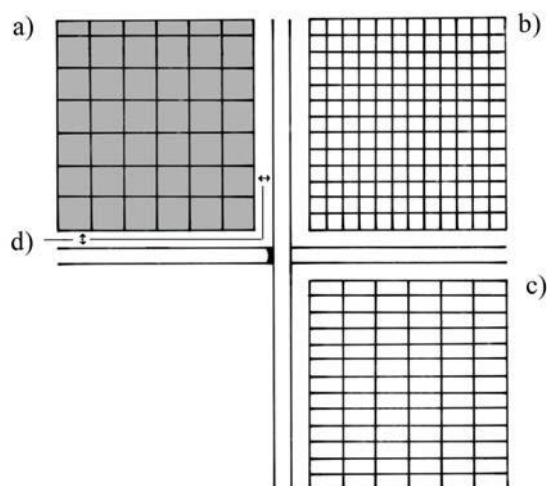

**Figure 3.** Containment screening.

a) 50 mm x 50 mm (max) openings with prescribed lining.

b) 25 mm x 25 mm (max) openings without prescribed lining.

c) 50 mm x 25 mm (max) openings without prescribed lining.

d) gap measured vertically and horizontally between the screen and the framework supporting it must not be over 25 mm.

## 2.6 Working platforms

Working platforms, except suspended scaffolds, should have duty classifications and dimensions complying with Section 2.3.2 *Loadings*.

Each scaffold should be designed to carry the required number of working platforms and to support its live loads.

The following are safe work practices or control measures for working platforms.

- Scaffold planks should:
  - comply with *AS 1577 Scaffold planks*
  - have a slip-resistant surface
  - not be cracked or split
  - be of uniform thickness
  - be captive (i.e. cannot be kicked off) and fixed to prevent uplift or displacement during normal use

- be positioned so that no single gap between planks exceeds 25 mm and the total gap between all planks does not exceed 50 mm.
- Planks should not be lapped on straight runs of modular and tube and coupler scaffolding but may be lapped on hanging bracket scaffolds.

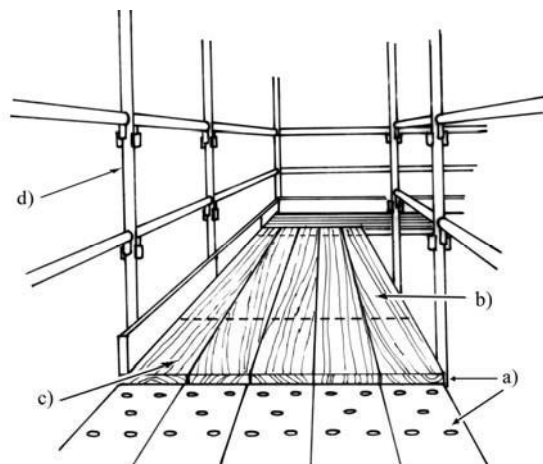

**Figure 4.** *Overlapping planks. Lapped scaffold planks may sometimes be used to cover gaps around corners of scaffold bays. These planks generally may not need to be secured, provided the following are met:*

- timber is lapped over metal planks.*
- planks are 1.2 metres long or greater.*
- plank overlap, past the edge of the plank underneath, is 300 mm or greater.*
- standards prevent planks from moving sideways on the scaffold.*

- If using plywood sheets to cover gaps between scaffold bays the plywood sheets should be:
  - a minimum of 17 mm thick
  - only used to cover gaps less than 500 mm wide (unless approved by an engineer)
  - secured.
- Planks should be secured as noted in Figure 4. Metal planks lapped on other metal planks should be avoided, but where they are used they should be secured using proprietary fixing or steel strapping. Other systems that are not structurally rated should not be used to secure planks on hop-up brackets.
- Plastic zip ties should only be used in non-load bearing situations to stop plank movement, where the force applied to a kickboard or plank is applied directly to a structural member in front or under the member. The load that can be applied to the kickboard or plank will then not be applied as a shearing load to the zip tie. In some situations, load-rated zip ties can potentially mislead workers into presuming they are adequate for a number of scaffolding applications. Unlike proprietary components, plastic zip ties have not been performance tested for structural scaffolding applications. While zip ties are load-rated, the load rating is only for tensile (pulling) loads and not for shear (cutting) loads. When used in load bearing situations, zip ties may be subjected to shear or tensile forces that are in excess of their maximum allowable load. Experience has demonstrated that zip ties can be cut through by the edges on scaffolding planks, such as when a worker's foot inadvertently makes contact with a scaffolding plank. See the [Zip ties on scaffolding](#) reference material online for further information.
- Apart from single board hop-up brackets, all hop-up brackets should be provided with tie bars to stop brackets from spreading apart and causing planks to dislodge, unless otherwise specified by the scaffold manufacturer. No single inadvertent force should be able to dislodge a tie bar pin (without a scaffolding plank sitting on top of the bar), or any part of a tie bar (e.g. a bouncing motion caused by an object falling down on the scaffolding deck). See the [Scaffolding hop-up bracket tie bars](#) reference material online for further information.
- Where hop-up planks are supported by a hop-up bracket on one end only, the method of support on the opposite side is to be approved by the scaffold designer. Where scaffold components are altered (e.g. altering of transoms to fix a hop-up bracket), an engineer should approve any alterations. All alternative methods of supporting a hop-up plank should ensure that the plank remains captive in the hop-up bracket.
- The overhang of planks which are supported by putlogs should be greater than 150 mm but less than 250 mm – otherwise uplift might occur.

- Avoid nailing or screwing laminated planks into position, unless otherwise specified by the manufacturer. Moisture penetrating the planks can cause damage and may not be easily detected.
- In cyclone prone areas all planks should be secured against uplift during cyclone season. In Queensland, cyclone prone areas include areas north of Bundaberg. Refer to *AS 1170 Structural Design Actions (Part 2)*.

## 2.7 The work environment

- WHS Regulation section 40:** A PCBU must ensure, so far as is reasonably practicable, that:
- the layout of the workplace allows, and is maintained to allow, persons to enter and exit the workplace and move within it safely, both under normal working conditions and in an emergency
  - work areas have space for work to be carried out safely
  - floors and other surfaces are designed, installed and maintained to allow work to be carried out safely
  - lighting enables each worker to carry out work safely, persons to move around safely and safe evacuation in an emergency
  - ventilation enables workers to carry out their work without risk to their health and safety
  - workers exposed to extremes of heat or cold are able to carry out work without risk to their health and safety
  - work in relation to or near essential services (such as gas, electricity, water, sewerage and telecommunications) do not affect the health and safety of persons at the workplace.

### 2.7.1 Access and egress

Workers must be provided with safe access to and egress from the scaffold at all times during the erection, use and dismantling of the scaffold.

An external perimeter scaffold with a TWP more than 8 m high (generally four lifts from the lowest ledger position) and a length of more than 60 lineal metres, should be provided with at least two means of access and egress, one of which should be suitable for emergency stretcher access. This does not include detached dwellings.

Common means of access and egress include:

- temporary stairs or portable ladder access systems installed at the start of erection, progressed with the scaffold, and used by the scaffolder wherever possible
- permanently installed platforms, ramps or ladders
- personnel hoists (non-mechanical forms of egress, such as a ladder or stair tower should be provided in case of emergency)
- using the existing floor level of a building, provided such access is safe
- using the existing permanent stairs of a structure, provided such access is safe.

Where the common means of access or egress is obstructed or unavailable, leaving no other form of access and egress, alternative temporary or fixed access and egress may include:

- existing internal floor access/stairwells
- use of a hoist if already available
- additional stair systems.

Where temporary stairways are used, they should be configured as follows:



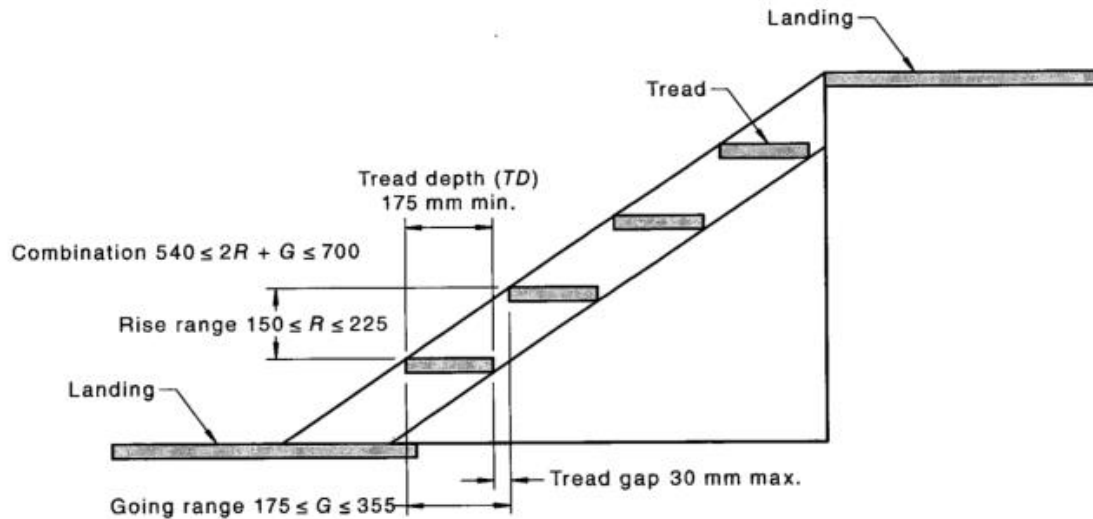

**Figure 5.** Temporary stairway configuration

Refer to *AS/NZS 1576.1* for further information on temporary stairways.

Additionally, where a temporary stairway is to be used for stretcher access:

- the slope of the stairway to the horizontal should be at an angle of 45° or less
- treads should be at least 1000 mm wide
- the length of a landing in the direction of travel should be at least 1200 mm and the width not less than the width of the stairway
- the upper surface of the external handrail or guardrail should be at least 1400 mm above the landing or top of each stair tread.

The scaffold designer should ensure the access system is designed for loads that could be applied in an emergency evacuation situation.

Access ways should be kept free of materials and rubbish to control the risk of falling objects.

Scaffolders should not climb standards except when harnessed and working on hung, cantilevered or spurred scaffolds, and other means of access/egress are not practical.

### 2.7.1.1 Step heights

Scaffold stairs are typically 1.5 m vertically in height and when constructed for a scaffold with 2 m lift heights, can create an issue with the final step height from the scaffold stair on to the working platform, and the step from the stair to the ground, being approximately 500 mm. The use of scaffold stairs that have a height of 2 m or reconfiguring the scaffold can address this issue. The step heights and goings in a scaffold stair system should be consistent within a straight run of steps between landings. Where there is a change in direction between landings, any difference in step height from the scaffold stair to an access or egress point should be minimised so that it is no more than 300 mm.

### 2.7.1.2 Ladders

The following are additional safe work practices which should be followed when using ladders:

- Ladders may be used where access to the working platform is needed by only a few people, and where tools and equipment can be delivered separately to the working platform (e.g. by materials hoist, crane or a rope and gin wheel).
- Ladders should be within a separate ladder access bay of the scaffold, wherever space permits.

- If the access bay is part of the working platform, a trap door is to be provided, except when erecting and dismantling, or where other controls are in place to prevent a person from inadvertently falling through the ladder access penetration from the main working platform. Strict controls are to be implemented to ensure the trap door remains closed while working from the platform. Workers should not be climbing over or under components to gain access to the working platform except when working on mobile scaffolds or where the TWP is 2.5 m or less.
- A swing arm or gate system should be installed to provide safe, clear access to working platforms and to stop a person falling back through the access bay.
- Ladders should be set up on a firm, level surface and not used on scaffold bays to gain extra height.

## 2.7.2 Lighting

Sufficient access lighting and task lighting must be provided, whether it is from a natural or artificial source, to allow safe movement around the workplace and to allow workers to perform their job without having to adopt awkward postures or strain their eyes to see. Additionally, emergency lighting must be provided for the safe evacuation of people in the event of an emergency.

The *Managing the work environment and facilities Code of Practice* provides guidance on the recommended illumination levels for various types of tasks, activities and interiors. See also Section 2.7 of *AS/NZS 3012* and *AS 2293.1* for further information on lighting.

## 2.7.3 Maintaining a safe work environment

**WHS Act section 19(3):** A PCBU must ensure, so far as is reasonably practicable, the provision and maintenance of a work environment without risks to health and safety, safe plant and structures, and safe systems of work, as well as the safe use, handling and storage of plant, structures and substances.

Good housekeeping practices when working on a scaffold are essential to prevent workplace injuries. Objects and debris left on a scaffold can fall and seriously injure workers and others, particularly during the process of dismantling the scaffold. A PCBU using a scaffold to undertake their work activities must, so far as is reasonably practicable, leave the area clean from falling objects, spills, waste, and other leftover materials such as food scraps, nails and hazardous substances.

Workers who disturb accumulations of dried bird droppings may be at risk of certain infectious diseases (e.g. psittacosis, cryptococcosis and histoplasmosis). Although uncommon, these may cause serious disease in some people. In particular, those who have a weakened immune system are at increased risk of complications from psittacosis, cryptococcosis and histoplasmosis. The risk from disturbing small amounts of fresh droppings is very low but increases if large accumulations of concentrated, dried droppings are disturbed.

Bird droppings are unlikely to accumulate in large concentrations on scaffolding that is only in place for a short period of time. Where scaffolding is to be in place for a long period of time at a location where birds are roosting or nesting the risk from disturbing accumulations of dried bird droppings should be considered. For example, a hanging scaffold on a bridge under repair which has birds nesting on it. Where there is a risk, advice on control measures can be found at [worksafe.qld.gov.au/work-with-bird-and-bat-droppings](https://www.worksafe.qld.gov.au/work-with-bird-and-bat-droppings).

The principal contractor for a construction project, or the PCBU with management or control of a construction site has ultimate responsibility for ensuring systems are in place to maintain a safe work environment on the scaffold and each PCBU using the scaffold leaves the scaffold without risks to health and safety.

## 3. Hazards

A number of hazards exist that have the potential to cause death or injury when working with scaffolding. These include:

- working near energised overhead electric lines
- mobile plant and traffic
- fixed plant
- mixing scaffold components
- falls from height
- falling objects
- scaffold collapse
- unauthorised access, use or alteration
- scaffold quality
- ground conditions
- hazardous manual tasks
- fire and explosion.

### 3.1 Working near energised overhead electric lines

Information about requirements for working near overhead electric lines is provided in the following:

- Electrical Safety Act 2002 (ES Act) – outlines general electrical safety duties
- Electrical Safety Regulation 2013 (ES Regulation) – states exclusion zones for working near overhead electric lines (note that consultation regarding the risks of the work should occur with the relevant electricity entity and other relevant parties)
- Electrical Safety Code of Practice – Working near overhead and underground electric lines – provides practical advice on safe systems of work and exclusion zones.

**ES Act section 30:** A PCBU must ensure its business is conducted in a way that is electrically safe. If the work involves working near overhead electric lines, the PCBU must ensure persons performing the work are electrically safe.

**ES Regulation section 11:** A PCBU must manage risks to health and safety associated with electrical risks at the workplace in accordance with the hierarchy of risk control in Part 3.1 of the WHS Regulation.

Before carrying out scaffolding work, a worksite inspection should be conducted to identify potential electrical hazards including energised overhead electric lines or associated electrical equipment (e.g. cables concealed behind a surface where an anchor is to be fitted). Consultation regarding the risks of the work should occur with all relevant parties involved in the work. Once the risks associated with overhead electric lines have been identified and assessed, appropriate control measures must be put in place.

The most effective way to eliminate any risk of electric shock or electrocution is by turning off the power. The PCBU and the principal contractor should discuss options for de-energising or re-routing the electricity supply with the relevant electricity entity. These options are the most effective control measures and should be considered before anything else. The PCBU and principal contractor should also consult with each other to ensure the electricity entity has been contacted.

De-energising or re-routing overhead electric lines should be arranged with the electricity entity as quickly as possible as this can take some time to arrange. Where overhead electric lines have been de-energised, written confirmation should be sought from the person in control of the electric line before undertaking any work.

If eliminating the risk is not reasonably practicable, the PCBU must consider using substitution, isolation, or engineering controls, or a combination of these control measures, to minimise the risk, in this order.

**ES Regulation section 68:** A PCBU at a workplace must ensure, so far as is reasonably practicable, that no person, plant or thing at the workplace comes within an unsafe distance of an overhead or underground electric line. If it is not reasonably practicable to ensure a safe distance, the PCBU must ensure that a risk assessment is conducted for the proposed work and the control measures implemented are consistent with the risk assessment and any requirements of an electrical entity responsible for the electric line.

**ES Regulation section 69:** A person comes within an unsafe distance of an overhead electric line if the person is within the exclusion zone for the person for the line.

If it is not reasonably practicable to turn off the power or re-route the electric line, the most effective control measure to reduce risk is to establish an exclusion zone that prevents people, plant, equipment and materials from coming close enough to energised overhead electric lines for direct contact or flash-over to occur.

An exclusion zone is a safety envelope around an overhead electric line and means the distance from the line for the person stated in Schedule 2 of the ES Regulation. A PCBU must ensure, so far as is reasonably practicable, that people, scaffold parts, and scaffolding equipment and materials do not enter into the exclusion zone.

When implementing a system to maintain the exclusion zone a number of factors should be considered, including:

- identifying the minimum clearance distance from the electric line to the closest person or part of the scaffold (the exclusion zone)
- allowing for sway or sag of the electric lines (sway is usually caused by wind, while sag may vary as the temperature of the line varies)
- ensuring that people and scaffolding stay outside the 'exclusion zone' at all times
- using a safety observer (commonly known as a 'spotter') who observes the scaffolding work if it is thought a person or part of the scaffold could possibly enter into the exclusion zone
- the potential for encroachment on the exclusion zone during the erection or dismantling of scaffolding, or once scaffolding is erected (e.g. while handling materials on the scaffold).

The identified minimum clearance distance may need to be greater than the prescribed exclusion zone distance to ensure there is no breach of the exclusion zone. It is important to note that the electricity entity may also specify a greater distance than the exclusion zones provided in Schedule 2 of the ES Regulation, if they consider the risk warrants it.

There are also a number of devices available to help prevent contact with electric lines, including:

- warning signs to indicate the location of overhead electric lines

- tiger tails or line markers on overhead electric lines to act as a visual aid to highlight the location of the electric line. (Note: tiger tails do not insulate wires and therefore the exclusion zone must be maintained).

## 3.2 Mobile plant and traffic

Mobile plant and vehicular traffic are hazards which can potentially affect worker safety and the safe use and structural integrity of a scaffold.

Outlined below are control measures that can be used to prevent or minimise exposure to the risk of death or injury from moving plant and traffic:

- Re-route motor vehicles and mobile plant away from the location of the scaffold (e.g. by using traffic controllers to redirect traffic).
- Use barricades, signs, posts, buffer rails, guards, or concrete or timber kerbs to prevent mobile plant and traffic from coming into contact with the scaffold.
- Ensure scaffolding does not have any unnecessary protrusions, such as over-length transoms, putlogs, tie tubes or over-height standards.

## 3.3 Fixed plant

Where fixed plant, such as tower cranes, operate in close proximity to a scaffold, there is a risk of loads snagging on the scaffold or endangering people on working platforms. Site-specific procedures should be developed to minimise the risks associated with fixed plant.

## 3.4 Mixing scaffold components

Components from different manufacturers or suppliers, while looking compatible, are often of different dimensions and tolerances. Mixing incompatible scaffold components can lead to difficulties in disassembly which in turn may increase the risk of musculoskeletal injury, increase wear on the components, and affect the load capacity of the scaffold.

Refer to Section 2.4 of *AS/NZS 1576.1* for further information on mixing scaffold components.

The following controls can be used to prevent or minimise the risk of injury and scaffold collapse due to the incorrect mixing of components:

- Do not mix scaffolding from different manufacturers, unless an engineer approves that:
  - the components are of compatible size and strength
  - the components have compatible deflection characteristics
  - the fixing devices are compatible
  - the mixing does not lessen the strength, stability, rigidity or suitability of the scaffold.
- See also *AS/NZS 4576 – Guidelines for Scaffolding* which sets out the assurances that are needed before the components of different prefabricated scaffolding systems can be mixed in a scaffold.

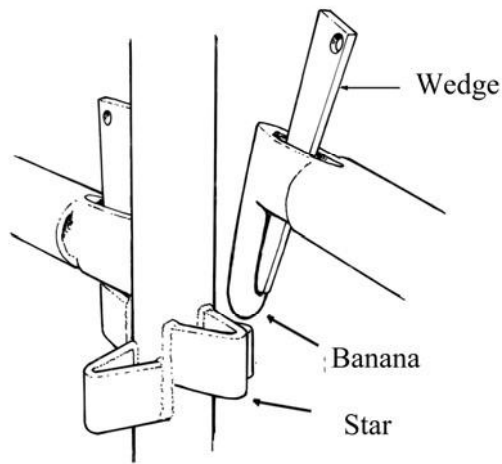

**Figure 6.** Mixing components. Avoid mixing different modular systems. Often connection points known as the 'star' and 'banana' used on these systems are of a different shape and tolerance and are not compatible.

- Do not mix scaffolding couplers and tubing of different outer diameters and strengths unless designed specifically for the task by an engineer or the coupler manufacturer has designed the couplers for this purpose. For example, do not mix aluminium and steel components as steel clamps may cause aluminium tubing to be crushed reducing the strength of the tube.
- 'Beam clamps' or 'flange clamps' should be provided with information about safe use, including tightening torque required and when to use different types of couplers. If no information is provided contact the supplier, manufacturer or designer of the scaffold.
- Stairs should be secured to the scaffold bay. If not secured, the supplier should provide documentation illustrating the maximum amount of clearance allowed between the transom and the top and bottom of the stair module.
- Ensure the gap between the end of a stair module and a transom is as small as practicable. Large gaps can lead to stairs dislodging and falling when a load is placed onto it. Gaps are not to exceed the maximum distance specified by the scaffolding designer and manufacturer. Where no instruction on the maximum allowable gap is provided, the gap between the stair module and the vertical edge of the transom should not be greater than 15 mm anywhere along the length of the transom. See the [Stair module failures on scaffolding](#) safety alert for more information.

## 3.5 Falls from height

A person who intends to erect, use or dismantle a scaffold must adopt control measures which eliminate, or at least minimise, the risk of a fall from height.

### 3.5.1 Risk of a fall at any height

**WHS Regulation section 78(1) and (2):** A PCBU must manage risks to health and safety associated with a fall by a person from one level to another that is reasonably likely to cause injury to the person or any other person. This includes the risk of a fall:

- in or on an elevated workplace from which a person could fall
- in the vicinity of an opening through which a person could fall
- in the vicinity of an edge over which a person could fall
- on a surface through which a person could fall
- in any other place from which a person could fall.

Before a person starts work to erect or dismantle a scaffold, they should:

- identify any hazards that may result in a fall, or cause death or injury from a fall
- assess the risk of death or injury
- implement control measures to prevent or minimise the level of exposure to the risk.

Hazards which may increase the risk of death or injury from a fall while erecting, altering or dismantling a scaffold include:

- poor environmental conditions, for example:
  - strong winds that may cause workers to lose balance
  - rain causing a slippery work surface
  - glare emitted from work surfaces and/or poor lighting affecting visibility
- materials, equipment or protruding objects below, or in adjoining work areas, for example:
  - pallets of construction materials
  - vertical reinforcing steel
  - a rubbish skip
  - exposed starter bars
  - picket fences
- void areas not identified or protected (e.g. ladder access voids)
- incomplete scaffolds or loose scaffold components where work is being done, or is likely to be done
- inadequate training, instruction and supervision of scaffold workers.

### 3.5.2 Risk of a fall when erecting scaffold

**WHS Regulation section 306P:** A PCBU must not erect or allow another person to erect scaffolding if there is a risk a person could fall 3m for housing construction work, or 2m for all other construction work, unless:

- a control measure prevents a person from falling
- a fall arrest system is used, or
- the PCBU otherwise complies with the process for erection described in section 306P(4) WHS Regulation.

Refer to Section 4 *Erecting, altering or dismantling scaffold* for information on safe work practices that should be followed when erecting a scaffold.

### 3.5.3 Risk of a fall when dismantling scaffold

**WHS Regulation section 306Q:** A PCBU must not dismantle or allow another person to dismantle scaffolding if there is a risk a person could fall 3m for housing construction work, or 2m for all other construction work, unless:

- a control measure prevents a person from falling
- a fall arrest system is used, or
- the PCBU otherwise complies with the process for dismantling described in section 306Q(3)(b) WHS Regulation.

Refer to Section 4 *Erecting, altering or dismantling scaffold* for information on safe work practices that should be followed when dismantling a scaffold.

### 3.5.4 Fall arresting platforms

A fall arresting platform can be used as a control measure to arrest a person's fall during work at height.

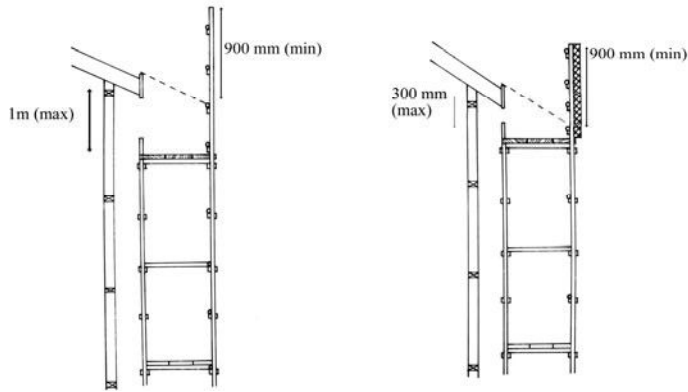

**Figure 7a** Fall arresting platform  $\leq 26^\circ$

**Figure 7b** Fall arresting platform  $> 26^\circ$

If the slope of the surface where work is being done is:

- not over  $26^\circ$  – then install the platform no more than one metre lower than the surface, or
- over  $26^\circ$  – then install the platform no more than 300 mm lower than the surface.

The fall arresting platform must:

- be unobstructed and at least 675 mm wide for the length of the platform
- be able to withstand the impact of a fall onto it
- have edge protection erected:
  - along the outer edge of the length of the platform
  - along the edges of each end of the fall arresting platform.

If the internal gap (the gap between the inner edge of the length of the platform and the face of the building or structure immediately beside the platform) exceeds 225 mm, then implement a control measure to control the risk of a fall.

### 3.5.5 Edge protection

Edge protection may be used as a control measure to prevent the risk of death or injury from a fall during work at height.

Obtain written approval from an engineer before installing edge protection on a scaffold system which was not originally designed, supplied or manufactured with edge protection. Approval should include specifications on how to install and maintain edge protection.

### 3.5.6 Fall-arrest systems

Fall-arrest systems can be used as a control measure to arrest a person's fall when working on a scaffold. However, fall-arrest systems are not usually appropriate for erecting a scaffold because:

- workers are likely to hit a component of the scaffold before the fall is arrested
- obtaining suitable anchorage points that can support a load of 15kN may be difficult
- continuously hooking on and off the scaffold may be inconvenient
- fall arrest lines may become trip hazards.

Fall-arrest systems should only be used during the following scaffold activities:

- erecting or dismantling 'drop' or 'hung' scaffolds where the scaffold is constructed from top to bottom, this allows for a clear fall zone, in the event of a fall
- the fixing and removal of trolley tracks on suspension rigs



- erecting or dismantling cantilevered needles and decking between the needles. Fall arrest systems could also be used during the erection of the first lift of scaffolding where workers are standing on the deck between the needles
- the erection and dismantling of cantilevered scaffolds prior to or when removing the initial platform
- the attachment and removal of spurs projecting from the supporting structure.

### 3.5.6.1 Rescue procedures for fall-arrest systems

Ensure that there are written procedures about safely retrieving a person who has fallen and ensuring the safety of the person involved in the retrieval.

In the event of an accident, the suspended person should be retrieved immediately – otherwise there is the risk of permanent injury to the person. Rescue procedures should also ensure the safety of the persons involved in the retrieval.

Emergency plans may need to identify the location and means of access for the rescuer.

A fall-arrest system should not be used unless there is at least one other person (or two people where the person who could fall is heavy and may be unconscious) on site who will be able to rescue the user.

If an elevating work platform (EWP) is to be used for a rescue, it should be readily available and be able to reach the position of the person using the fall-arrest system at all times.

Workers must be provided with training in the safe and correct use of the fall-arrest system.

## 3.6 Falling objects

**WHS Regulation section 54:** A PCBU at a workplace must manage risks to health and safety associated with an object falling on a person if the falling object is reasonably likely to injure the person.

**WHS Regulation section 315E:** For civil or housing construction work, if a PCBU uses a falling objects control measure, it must comply with requirements under this section.

**WHS Regulation section 315F:** For construction work that is not civil or housing construction work, a principal contractor must ensure that a relevant person identifies and decides the line (proposed line) along which any barricade or hoarding required is to be erected.

**WHS Regulation section 315G:** The principal contractor must ensure that certain additional control measures are implemented before construction work starts where the measured angle is 75° or more.

The erection, alteration, use and dismantling of a scaffold exposes workers and others to the risk of being struck by falling objects such as scaffold components, tools, or in the event of a collapse, the entire scaffold.

The control measures that are implemented should firstly aim to prevent objects from falling, but equally prevent injury if an object has fallen. Small objects, such as bolts and concrete aggregate, falling from a height can cause serious injury.

The following are examples of control measures that may be used to prevent or minimise exposure to the risk of being hit by falling objects.

- Establish exclusion zones around scaffolding and adjoining areas to prevent unauthorised persons from accessing the area.
- Use perimeter containment screening (see Section 2.5 *Perimeter containment screening*), scaffold fans, hoardings or gantries to contain falling objects.
- In built-up areas, erect and dismantle scaffolding during quiet times.
- Use mechanical hoists to move materials.
- Attach danger tags and warning signs such as ‘Keep Out – Falling Objects’ and ‘Danger – Incomplete Scaffolding’ in obvious locations to warn persons of hazards.
- Consult with all relevant parties before work starts.
- Implement good housekeeping practices (see Section 2.7.3 *Maintaining a safe work environment* for further information).

Materials should not be dropped from a scaffold. When passing scaffolding from one level to another, this should be done internally within the scaffold, unless suitable exclusion zones are maintained.

### 3.6.1 Preventing objects from falling

Controls should be applied at the source to prevent objects from falling, that is, eliminate the risk. This is the most effective control to prevent injury or death caused by falling objects.

Good housekeeping practices are an effective way of preventing small objects from falling. Ensure items are cleaned up and kept away from edges and stairways. Particular attention in working areas should be given to prevent objects falling onto access ways below.

### 3.6.2 Gaps

There is almost always a gap between the working face of a scaffold and the building or structure being constructed (internal gap). *AS/NZS 1576.1 Scaffolding – General Requirements* allows a distance of 100 mm – 225 mm from the scaffold working deck to the building structure horizontally, a 300 mm gap vertically from the top of a floor level and a 300 mm gap from the underside of a soffit level.

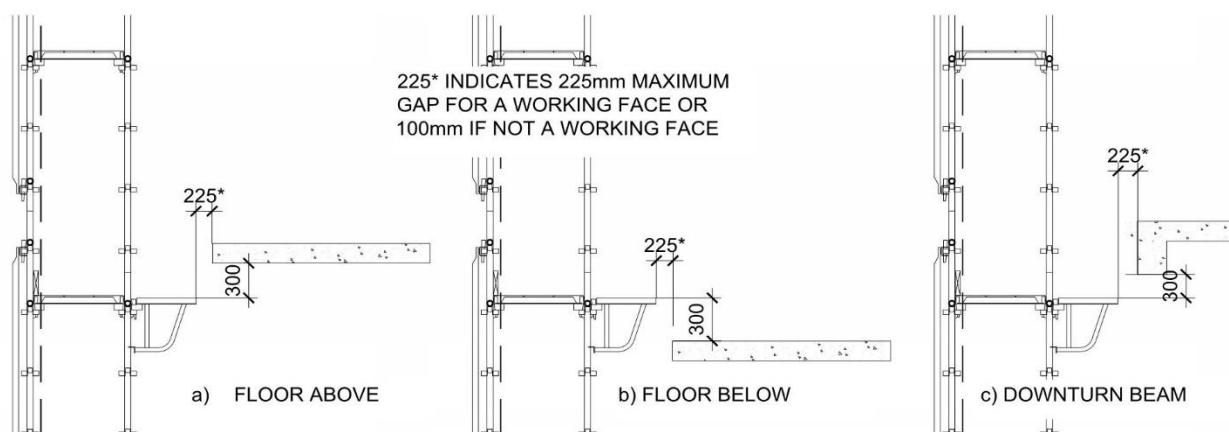

**Figure 8** Allowable gaps

Consideration should be given to implementing a control to close gaps where work activities are being undertaken above or alongside them. Gaps should be eliminated over common access and egress points.

There can sometimes be uncertainty between construction site duty holders about who is responsible for managing the risks posed by scaffold gaps. Initially, the scaffolder is responsible for ensuring the scaffold is compliant during its construction, and before handover and use by other workers. The person who commissioned the scaffold has a duty to ensure the scaffolding work does not adversely impact on the health and safety of other workers on the site during this time. In addition, the scaffold should be monitored and maintained for the duration of its use to account for factors such as unauthorised alteration, overloading, and adverse environmental conditions. All PCBUs must ensure the safety of their workers and others when using the scaffold.

### 3.7 Scaffold collapse

See Section 5 *Types of scaffold* for control measures which may be used to prevent or minimise exposure to the risk of death or injury from scaffold collapse. See also Section 2.3 *Foundations* regarding the prevention of collapse due to ground conditions and loadings.

### 3.8 Unauthorised access, use or alteration

**WHS Regulation section 203:** A person with management or control of scaffolding at a workplace must manage risks to health and safety.

**WHS Regulation section 205:** The person with management or control of scaffolding must, so far as is reasonably practicable, prevent alterations to or interference with the scaffold that is not authorised by that person.

**WHS Regulation section 225:** Suspended, cantilevered, spur, hung and other scaffold from which a person or thing can fall more than four metres must be inspected by a competent person before use, before the resumption of use after an incident or repairs, and at least every 30 days. Unauthorised access to these types of scaffold must be prevented while the scaffold is incomplete or unattended.

The unauthorised access, use or alteration of a scaffold can affect its integrity and introduce significant hazards and risks (e.g. the risk of a worker falling from height, if a part of the structure is removed).

A scaffold can be in place for a significant length of time, with many different workers from various trades having access to and using the scaffold. This provides many opportunities for the scaffold to be altered or tampered with without the person with management and control of the scaffold being aware. A scaffold may be altered, for example, to provide ease of access while undertaking specific work activities, and the consequences of these alterations may not be understood.

See Section 4.2 *Scaffold alteration* for further information about control measures to minimise the risk of death or injury during scaffold alteration.

### 3.9 Scaffold quality

Scaffolding should preferably be constructed from materials that are resistant to corrosion and weathering. Painted steel scaffolding components are more susceptible to corrosion than galvanised and aluminium scaffolding. However, the scaffold designer should also consider the durability of the structure and the potential loading applied during dismantling and erection. For example, although aluminium is more corrosion resistant than non-galvanised steel, it may be more susceptible to damage.

A competent person should thoroughly inspect all scaffolding components to determine their condition prior to erection. The inspection should include the overall condition, the surface coatings to prevent corrosion, and welding and fabrication issues.

Scaffolding components are generally not designed to be in humid and/or coastal locations for long periods of time. In these instances, corrosion can occur to critical parts of the structure, such as support nodes for platforms, and platforms can collapse without warning. Visual inspection may be unable to identify all corroded areas (e.g. where the bottom of scaffolding standards are filled with water causing internal corrosion).

PCBUs should refer to manufacturer's specifications for product maintenance, repair and fitness for use information. An appropriate inspection and maintenance regime should be developed based on this information.



**Figure 9** Severe corrosion on critical scaffolding components

## 3.10 Ground conditions

See Section 2.3.1 *Ground conditions* for further information.

## 3.11 Hazardous manual tasks

Guidance on hazardous manual tasks is available in the *Hazardous manual tasks Code of Practice*.

### 3.11.1 Examples of design controls

#### **Job design and redesign**

- Where appropriate, use scaffold systems which are made of lighter weight materials and use modern technologies (e.g. modular systems which have shorter standard lengths or systems that are made of aluminium rather than steel or timber).
- Store scaffolding components as close as practical to the work area in order to minimise the distance over which loads are manually moved. Clear access ways should also be ensured so that materials and equipment can be easily accessed.
- Use the appropriate tools for the work performed and avoid over tightening scaffold couplers which results in the need for greater force when loosening them during the dismantling stage.

#### **Mechanical aids**

- Use mechanical aids such as cranes, hoists, pallet jacks or trolleys to move equipment and materials wherever possible (e.g. when lifting bundles of components, moving components/materials around the site, or unloading vehicles).
- Team lifting is not a preferred method for load handling and should only be used as a last resort when mechanical aids cannot be used, or the work cannot be redesigned. Workers should be trained in team lifting techniques and adequate numbers of workers should be provided.
- Use electric winches (preferred) or gin wheels to lift components up the scaffold.

### 3.11.2 Examples of administrative controls

#### **Work organisation**

- Incorporate rest breaks or task variety into the job where the risk cannot be prevented or minimised.
- Ensure there are adequate numbers of workers to meet deadlines.

#### **Task specific training**

- Workers should be provided with education and training in relation to the performance of manual tasks. This includes training in the correct use of mechanical devices, tools and equipment, as well as safe performance of the specific manual tasks and handling methods (e.g. team lifting).

#### **Preventative maintenance program**

- Clean and maintain tools, equipment and scaffolding components regularly. Tools and equipment which are not properly maintained, as well as components that have been damaged and therefore no longer fit easily together, may require increased force when using them.

#### **Personal protective equipment (PPE)**

- PPE and clothing can increase the potential for injury if it is lacking or unsuitable for the work performed (e.g. incorrectly sized gloves interfere with a worker's gripping ability and manual dexterity and this contributes to increased muscular effort and fatigue). If gloves are worn it is important that the appropriate type of glove is chosen based upon the work requirements and different sizes are provided so that the right size for the worker can be selected.

## 3.12 Fire and explosion

Fire and explosion can result in catastrophic consequences, causing serious injuries or death to workers or others, as well as significant property damage. Many materials and substances found in workplaces are flammable or combustible, including some types of perimeter containment screening.

Suppliers must ensure so far as is reasonably practicable that any material or substance supplied is without risk to the health and safety of workers or others. This should include carrying out all necessary testing, and providing adequate information to all relevant people about any flammability properties identified and the conditions necessary to ensure the material or substance is without risks to health and safety (e.g. restricting the use of the material to a certain height). Designers, manufacturers and importers have similar duties.

Principal contractors also have duties to ensure the risks associated with fire and explosion are managed so far as is reasonably practicable. This should include ensuring work undertaken in proximity to certain materials and substances, such as perimeter containment screening, does not use possible ignition sources without appropriate protection (e.g. shields for hot works).

## 4. Erecting, altering or dismantling scaffold

### 4.1 Safe erection of scaffold

The following safe work practices should be followed when erecting a scaffold.

- Scaffold 'fittings' and other connections should be securely tightened (but not over-tightened). Where 'safety fittings' are used, they should be fitted in accordance with the scaffold plan.
- All scaffold components and access provisions should be installed as the scaffold is erected. For example, the installation of:
  - all bracing and ties
  - guy ropes or buttresses.
- Consider using specifically designed loading platforms and/or back propping to prevent overloading the building floor or the scaffold.
- Obtain certification from an engineer before erecting a scaffold on awnings or other structures such as roofs or suspended floors.
- Limit the number of workers on a scaffold at any one time.
- Develop a methodical work sequence if more than one worker will be on the scaffold at the one time (e.g. allocate specific tasks to each scaffolder).
- Work from a full deck of planks whenever possible.
- Do not climb on guardrails to gain extra height.
- Where the internal gap on scaffolding (includes hanging bracket scaffolding) is greater than 225 mm, put in place measures to control the risk of a fall. For example, install:
  - edge protection on the inside edge of the platform
  - additional scaffold planks to minimise the size of the internal gap.

An example of scaffold erection is shown in Figure 10. In this example the scaffold is being erected against an existing building so guardrails are only needed on external faces. Access ladders and toeboards have been omitted for clarity.

After enough components of the scaffold have been erected to support it, immediately install:

- a platform at least 450 mm wide along the full length of the section of scaffold
- edge protection across the space between the standards forming the outer frame of the scaffold at the level the scaffold has reached
- a way to access the scaffold (e.g. temporary stairs or a ladder to the level the scaffold has reached).

Before the next level of the scaffold is erected, a platform should be installed not more than two metres below the position of the next level. A section of the platform may be left open to allow the passing of planks or other scaffolding between levels. A platform may be removed after work has started two levels above the level from which the platform is to be removed.



**Figure 10** Scaffold erection<sup>2</sup>

<sup>2</sup> Sourced from the Safe Work Australia document, *General guide for scaffolds and scaffolding work*.

## 4.2 Scaffold alteration

Control measures to minimise the risk of death or injury during scaffold alteration include ensuring:

- the scaffold designer is consulted before making any alterations
- only a competent person makes scaffold alterations
- scaffold alterations are in accordance with the scaffold plan
- alterations do not compromise the structural integrity of the scaffold
- systems are in place (e.g. regular inspections) to identify unauthorised interference with the scaffold.

For any alterations to a scaffold over four metres, details of the alteration, including what was altered, by who and when, should be recorded on the scaffold handover certificate.

## 4.3 Safe dismantling of scaffold

The following safe work practices should be followed when dismantling a scaffold.

- Edge protection and any means of access can be removed as the scaffold is dismantled, provided it is removed at the last possible stage.
- A platform of at least 450 mm wide, at the level the dismantling has reached, should be in place, where practicable.
- Ensure that when dismantling a scaffold, a full set of planks is directly under the worker at a vertical distance of no more than two metres.
- To prevent death or injury to persons and damage to components, do not drop scaffolding components from heights when dismantling a scaffold.

The person with management or control (PWMC) of the scaffold immediately prior to it being dismantled and the PCBU undertaking the dismantling of the scaffold, must manage risks to the health and safety of workers dismantling the scaffold, and others that could be impacted by the risks, in accordance with part 3.1 of the WHS Regulation. Falling objects can pose a significant risk and cause serious injuries to workers and others when dismantling a scaffold. Good housekeeping practices on and around scaffolds must be implemented by all PCBUs (e.g. each PCBU ensuring objects and debris left by them on a scaffold are removed before they leave site), and enforced by the PWMC of the scaffold on site, to eliminate the risk of objects and debris falling during dismantle, so far as is reasonably practicable.

See Section 2.7.3 *Maintaining a safe work environment* for further information about housekeeping responsibilities.

See Section 3.6 *Falling objects* for further information about managing risks to health and safety associated with falling objects.

## 5. Types of scaffold

Consider the design, shape and location of the building or other structure when selecting the type of scaffold to be used. Choose a scaffold system that is most adaptable to the contour of the building or other structure, particularly if a modular scaffold is being considered. Also consider the purpose for which the scaffold is to be used (e.g. bricklaying, plastering or demolition).

The following section identifies different types of scaffolds and control measures to prevent or minimise exposure to the risk of death or injury.

Scaffolds should be erected in accordance with the designer's instructions and the scaffold plan.

A person doing scaffolding work where they could fall more than four metres in height must hold a basic, intermediate or advanced scaffolding high risk work licence, as outlined in Schedule 3 of the WHS Regulation.

See Section 6 *Inspection and maintenance procedures* for information regarding the inspection and maintenance of scaffolds to ensure they remain in a safe condition.

### 5.1 Independent scaffold

An independent scaffold consists of two or more rows of standards connected longitudinally and transversely.

#### 5.1.1 Birdcage scaffold

A birdcage scaffold is an independent scaffold that consists of more than two rows of standards in both directions and is connected by ledgers and transoms. It is mainly used for work that is to be carried out on a single level, such as ceilings.

Refer to the designer's specifications when erecting and dismantling birdcage scaffolds made from modular scaffolding.

The following control measures should be implemented for birdcage scaffolds made from tube and coupler scaffolding:

- Provide untied birdcage scaffolds with lengthwise bracing at each outer longitudinal row of standards.
- Only use birdcage scaffold to support formwork that has been specifically designed for this purpose.
- Provide longitudinal bracing or a tied face at every third longitudinal row of standards.
- Brace the outside row of standards on each face and each third row internally with longitudinal bracing.
- Provide transverse bracing at every fourth bay on the ends of the scaffold.
- Use scissor lifts to erect or dismantle birdcage scaffolds.

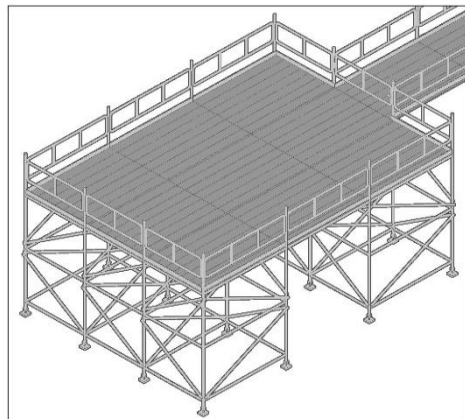

**Figure 11** Birdcage scaffold<sup>3</sup>

<sup>3</sup> Sourced from the Safe Work Australia document, *Guide to scaffolds and scaffolding*.



A fall arrest system is generally not an appropriate control measure for the erection or dismantling of perimeter and birdcage scaffolds (see Section 3.5.6 *Fall-arrest systems* for further information). Use another control measure to prevent or minimise exposure to the risk of death or injury from a fall.

### 5.1.2 Tower scaffold

A tower scaffold is an independent scaffold consisting of four vertical members connected longitudinally and transversely.

The following control measures should be implemented for tower scaffolds:

- Construct the tower with modular, frame, or tube and coupler scaffolding.
- Ensure the tower is resting on firm level ground with the wheels or feet properly supported. Do not use bricks or building blocks to take the weight of any part of the tower.
- Consider environmental factors when determining the height of the scaffold relative to the base dimension. Ensure the working height is no greater than specified by the manufacturer or designer.
- Use alternative height to base ratios or extra support if the scaffold is:
  - sheeted or likely to be exposed to strong winds
  - loaded with heavy equipment or materials
  - used to hoist heavy materials or support rubbish chutes
  - used for operations involving heavy or awkward equipment (e.g. grit blasting or water-jetting)
  - supporting a ladder.

### 5.1.3 Mobile scaffold

A mobile scaffold is an independent scaffold that is freestanding and mounted on castors.

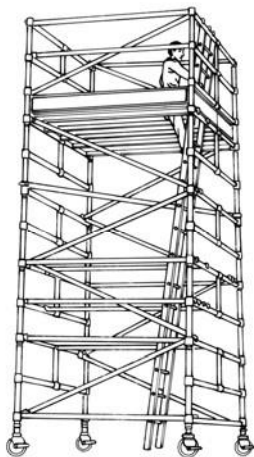

**Figure 12** Mobile scaffold

Mobile scaffolds must be supplied with information regarding their safe use and erection. If the scaffold is to be altered, contact the manufacturer or supplier for additional guidance. All modular mobile scaffolds are to be erected in accordance with manufacturer's specifications.

The following control measures should be implemented for mobile scaffolds:

- Consider environmental factors when determining the height of the scaffold relative to the base dimension.
- Ensure the working height is no greater than specified by the manufacturer or designer.
- Where adjustable castors are used, the slope of the surface should not exceed three degrees, unless otherwise specified by the manufacturer.

- Ensure that the mobile scaffold has safe access. Where the height of the working platform permits, use a secure internal ladder with a protected opening (e.g. a hinged trap door) for access and egress to and from the scaffold.
- Select the appropriate size and capacity castors to support the total mass of the dead and live loads of the scaffold.
- Use castors that have the working load limit clearly marked.
- Castors fitted to standards should be locked before erection continues.
- Castors with adjustable legs should be used and adjusted to keep the platform level when the supporting structure is at different heights.
- Incorporate plan bracing at the base of mobile scaffolds to provide greater stability.
- Before moving mobile scaffolds check that:
  - there are no power lines or other overhead obstructions
  - the ground is firm and level
  - no person is on the scaffold
  - no equipment and material can be dislodged from the platform
  - the supporting surface is free of obstructions (a small obstruction may cause a mobile scaffold to overturn)
  - electrical equipment and leads cannot be tangled.
- Brakes on castors are to be locked at all times unless moving the scaffold.
- Never move the scaffold in windy conditions.
- Push or pull the mobile scaffold from the base – never use powered vehicles to move the scaffold.
- If lifting a mobile scaffold by crane, sling the scaffold at its lowest point to prevent dislodgment of scaffold components. However, a crane should not be used to lift aluminium mobile scaffolds because the scaffold components may fail.

#### 5.1.4 Hung scaffold

A hung scaffold is an independent scaffold that hangs from another structure, but is not capable of being raised or lowered when in use. An advanced scaffolding high risk work licence is required when undertaking scaffolding work involving hung scaffolds.

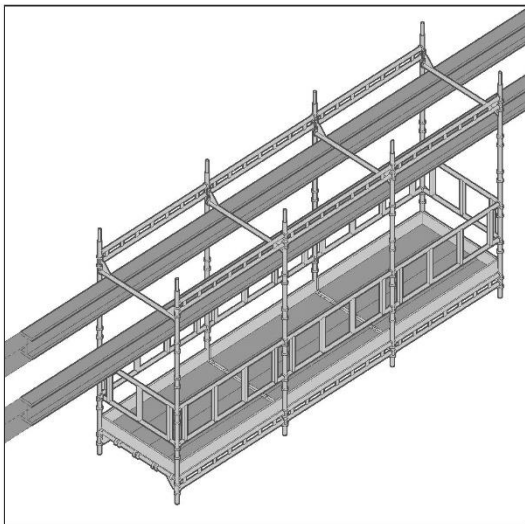

**Figure 13** Hung scaffold<sup>4</sup>

The following control measures should be implemented for a hung scaffold:

- The hung scaffold should be designed by a person as nominated in Table 1 and verification obtained that the structure that is to support the hung scaffold is capable of bearing the load.
- The scaffold plan should include information about the position of the safety couplers.
- If a cantilevered suspension rig is to be used, information should be included on how the rig is to be constructed and secured.
- Standards on a hung scaffold should be tension spliced (refer to Figure 1).
- All vertical hanging tubes are to be provided with safety couplers at the suspension points and underneath the platform.

<sup>4</sup> Sourced from the Safe Work Australia document, *Guide to scaffolds and scaffolding*.

## 5.2 Single pole scaffold

A single pole scaffold consists of a single row of standards connected by ledgers. Putlogs are fixed to the ledgers and built into the wall of the building or structure.

A single pole scaffold is dependent upon the structure against which it is placed for support. It is important that no components of this type of scaffold are removed until the scaffold is being dismantled.

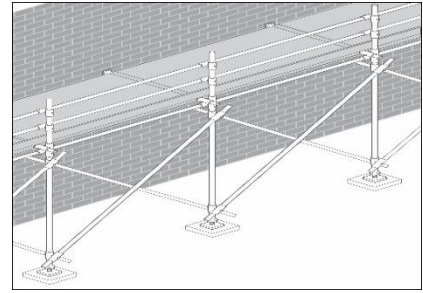

Figure 14 Single pole scaffold<sup>5</sup>

## 5.3 Suspended (swing-stage) scaffold

A suspended scaffold incorporates a suspended platform that is capable of being raised or lowered when in use. An example of a suspended scaffold is a swing-stage scaffold.

A summary of the requirements for suspended (swing-stage) scaffold are listed in this part. *Appendix 5: Compliance pack for suspended (swing-stage) scaffolds* of this code provides a package of information and safety requirements to be followed. In addition, any relevant component manufacturers' requirements and specific engineer requirements for each installation should be followed.

A person installing (erecting, altering or dismantling) a suspended scaffold must have an advanced scaffolding or rigging high risk work licence, and must be competent in the installation of suspended scaffolds. A person who has successfully completed the *CPCCLSF4001A – Licence to erect, alter and dismantle scaffolding advanced level* course (or any subsequent, equivalent course) is generally considered to have the required competence. A person using a suspended scaffold should undertake a *Course in the Safe Use of Swing Stage Scaffolds* or a subsequent, equivalent course.

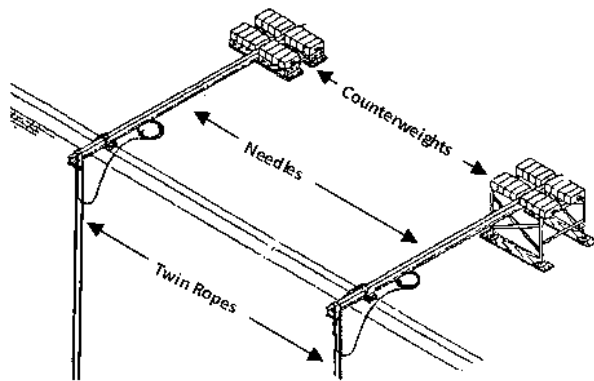
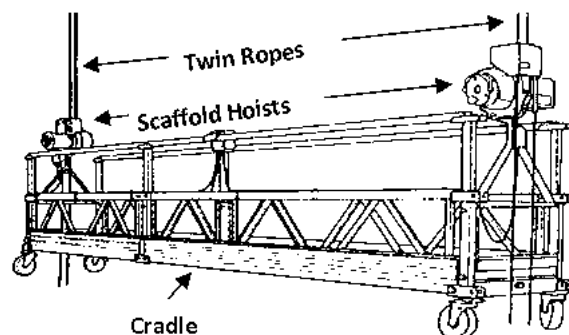

Figure 15b. Suspended (swing-stage) scaffold – Cradle (suspended) end

Figure 15a. Suspended (swing-stage) scaffold – Suspension mounting



The following control measures should be implemented for a suspended scaffold:

- Ensure safe access to and egress from the cradle.
- Consult and instruct workers on the correct procedures for using and working on suspended scaffolds. Include instructions on all safety features including emergency

<sup>5</sup> Sourced from the Safe Work Australia document, *Guide to scaffolds and scaffolding*.

stop, load limiting device, and rope lock device, as well as raising and lowering operations, particularly in the event of an emergency (e.g. power failure).

- Ensure a rescue and retrieval procedure is developed before starting work.
- Suspended scaffold components should be inspected for damage, wear and cracks before use and at pre-determined intervals. See Section 6 *Inspection and maintenance procedures* for further information. Non-destructive testing for cracks in high stress areas (e.g. dye penetrant testing) may be needed to identify cracks not easily visible. This should be done every three years.

### 5.3.1 Design issues

Component control measures for each component of a suspended scaffold include the following:

- Suspended scaffolds should be designed by a suitably qualified and experienced engineer.
- The suspension system and the cradle should be designed to withstand 1.25 times the stalling load applied by all scaffold hoists in use. This feature prevents failure in the event of the cradle snagging on an obstruction. A twin rope hoist motor should be used.

### 5.3.2 Counterweight calculation

The number of counterweights needed on each needle of a cantilevered suspension rig is calculated using the following formula:

Number of counterweights =  $3 \times (\text{rope tension in kg}) \times (\text{outboard in mm}) \div (\text{inboard in mm}) \div (\text{mass of each counterweight in kg})$

An example of a calculation of the number of counterweights (assuming each counterweight weighs 25 kg) is as follows:

Maximum rope tension = 723 kg

Outboard = 900 mm

Inboard = 3600 mm

Therefore:  $3 \times 723 \times 900 \div 3600 \div 25 = 21.69$  (22 counterweights per needle)

Refer to AS/NZS 1576.4 for further information on counterweight calculation.

### 5.3.3 Method of fixing needles

The method of fixing the suspension needles is to be clearly shown on a detailed drawing that has been certified by an engineer. The following options apply for fixing the inboard length of the needles to the structure:

- Where the needle is fixed to the floor the fixing is to be positively restrained – chemical and friction type anchors are not to be used (e.g. a u-bolt fitted over the needle and through the concrete floor slab could be used).
- Scaffold couplers should not be used to secure the counterweight or other anchorage to the rear of the needle (see Figure 15a). A positive connection, which does not rely on friction, is to be used. One example is a bolted or pinned connection where the bolt or pin passes through the structural members and is prevented from accidental removal with a nut or other locking system (e.g. split pin or 'R' clip).
- If the needle is attached to an anchorage point or existing structure on the building, the anchorage system and method of attaching the needle are to be engineer certified. Restrain the back of the needle to an engineer certified anchorage point.
- Where props are used these are to be installed to the top of the needle and to the underside of the floor above. Ensure the props are fixed to prevent dislodgement. The

floors should be certified by an engineer to be able to safely withstand the point loading applied by the props.

- Where counterweights are used, these are to be adequately secured by keyed lock, and preferably on top of the needle.

### 5.3.4 Suspension systems

- Ensure the suspension system is designed and constructed in accordance with the designer's specifications.
- Inspect the suspension system before use and after relocation to ensure all components are secure and in working order.
- Ensure persons who use suspended scaffolds are competent and receive training and instruction on the safe use of the system, including information on hoist operation and emergency procedures.
- Obtain engineer certification that the suspension needles, parapets, roof structure or other parts of the structure can support the 'parapet clamps' or outriggers. An example of an unsuitable support system would be timber or single skin brick parapets.
- Access to the suspension system should be restricted to persons involved in the work. The person in control of the suspension system area (principal contractor and/or body corporate) should ensure the restriction is in place. Access can be restricted by:
  - erecting signs and barricading (e.g. warning tape, barrier mesh/parawebbing, or temporary fencing) around the suspension rig where it is located in an already partially restricted area
  - the use of permit-to-work systems in the restricted area
  - locking off access doors and hatches to the roof, balcony or other area where the suspension system is located.
- Ensure counterweights are secured to prevent unauthorised removal.
- Suspension ropes should be inspected for damage such as kinks, wear, corroded or broken wires, and replaced if necessary. See *AS 2759 – Steel wire rope—Use, operation and maintenance* for guidance.

### 5.3.5 Scaffold hoists

- Ensure scaffold hoists comply with the manufacturer's specifications. Only suspension ropes noted in the specifications (compliance plate attached to the hoist) should be used.
- Ensure scaffold hoists comply with *AS 1418.2 Cranes (including hoists and winches) – Serial hoists and winches*.
- After each use, ensure a trained person inspects and checks scaffold hoists, in accordance with the manufacturer's instructions.
- Electric scaffold hoists should have a device to limit the lifting capacity of the hoist to a maximum of 1.25 times the rating of the hoist, as specified in *AS/NZS 1576.4 Scaffolding – Suspended scaffolding*. The scaffold hoist limiting device should be tested to the manufacturer's instructions prior to use and this should be documented.
- Main and secondary hoist ropes are to be independently connected to the needle in case of failure of one of the ropes. This can be achieved by connecting each rope to a separate connection point on the needle (e.g. a different stirrup).

### 5.3.6 Cradles

- Cradles are to be constructed in accordance with the manufacturer's specifications.
- Inspect all connection fixings before use to check they are secure.
- Evenly distribute materials in the cradle.
- Cradles should be clearly marked with the working load limit (WLL). The length and type of material used to construct the cradle will influence the WLL of the cradle. Verify

the WLL with the manufacturer or supplier where there are no clear markings on the cradle.

- If the cradle varies from the original manufacturer's specifications, a suitably qualified and experienced engineer should verify the modification before use.
- To restrict the lateral movement of the cradle, use suction caps, and tie off the cradle with rope.
- Work should cease and the cradle should be lowered to the ground during windy conditions. The maximum allowable operating wind speed should be documented.

### 5.3.7 Trolleys

To prevent a trolley from falling off the beam, use lower keeper plates or a strap that wraps around the top of the beam. Trolleys that are not fitted with such a system should be removed from service. Obtain guidance from manufacturers and designers on effective systems to use.

### 5.3.8 Fall-arrest and travel restraint harness systems

- Persons located in swing-stage cradles are to wear fall-arrest harnesses attached to a properly designed anchorage system. However, the harnesses may be used in a travel restraint application, attached to a static line in the cradle, where a fall out of the cradle is not possible. A thorough assessment needs to be undertaken to ensure appropriate control measures are in place to address any secondary risks that might arise.
- Where the guardrail or other edge protection is not provided for scaffolders erecting the suspension system, fall-arrest systems are to be used. This includes, erecting or dismantling swing-stage scaffold components, or when doing preparatory or quoting activities where other positive fall prevention (such as staying on the safe side of a 900 mm parapet) is not used.
- If independently anchored safety lines are used, then a high level of training and rescue procedures should be in place.
- Wherever fall-arrest systems are used, a rescue procedure must be developed and should be documented. The rescue procedure should not place others at risk of injury.
- Fall-arrest systems must comply with the WHS Regulation.

*Appendix 5: Compliance pack for suspended (swing-stage) scaffolds* at the end of this code provides a package of safety information to be followed.

## 5.4 Complex scaffolds

### 5.4.1 Cantilever scaffold

A cantilever scaffold is a scaffold that is supported by cantilevered load-bearing members. An intermediate or advanced scaffolding high risk work licence is required when undertaking scaffolding work involving cantilevered scaffolds.

The following control measures should be implemented for a cantilevered scaffold:

- Design and position cantilever beams in accordance with the engineer's requirements and the scaffold plan.
- Ensure a competent person certifies that the supporting structure can support the cantilevered scaffold.
- The following are preferred methods for fixing the inboard length of the cantilevered beam to the structure:
  - fix the beam to the floor below using a positive fixing (e.g. a u-bolt fitted over the beam and through the concrete floor slab)
  - use counterweights on the beam, or
  - install props to the top of the beam and to the underside of the floor above. Ensure the props are fixed to prevent dislodgement.

## 5.4.2 Hanging bracket scaffold

Hanging bracket scaffolds are systems supported by frames on buildings or other structures. Hanging brackets are sometimes in the shape of an upside down 'L'; one arm is fixed to a vertical surface, the other projecting horizontally to support scaffold planks.

Other hanging bracket scaffold systems may include horizontal members that are supported by floors of buildings or other structures.

The following control measures should be implemented for hanging bracket scaffolds:

- Hanging bracket scaffolds and their means of support should be designed by an engineer. Engineering verification may be provided by calculation and/or load testing.
- The supporting structure should be able to support dead and live loads applied by the hanging brackets. The supporting structure is to be verified by a competent person as sufficiently complete prior to erection of the scaffold.
- Spacing of brackets should not exceed the maximum plank spans specified by the manufacturer.
- Planks may overlap planks on straight runs on hanging bracket scaffolds, provided the overlap is at least 300 mm. Note: This does not refer to overlap of planks on putlogs. Minimum and maximum overlapping for planks on putlogs is provided in *AS/NZS 1576 Scaffolding*.
- A safe means of access for persons installing hanging brackets should be provided. Where fall-arrest systems are used, these must comply with the WHS Regulation.
- Connectors are used where differential deflection<sup>6</sup> causes a tripping hazard.

## 5.4.3 Spur scaffold

A spur scaffold is a scaffold that is supported by inclined load-bearing members. An intermediate or advanced scaffolding high risk work licence is required when undertaking scaffolding work involving spur scaffolds.

The following control measures should be implemented for a spur scaffold:

- Fix propping systems between the floor and ceiling at intervals to suit the spacing of the standards within the scaffold.
- Suitable headstocks should be provided at the top of each propping system to distribute the loads imposed.
- All propping systems should be securely tied together and braced.
- Spurs exceeding 1.8 metres in length should be braced in both directions at the centre, unless designed otherwise.

## 5.5 Scaffolding for demolition work

At a minimum, heavy or special duty scaffolding should be used during demolition work to contain dislodged materials or to provide a safe working platform and edge protection for workers.

Factors which affect the stability of scaffolding for demolition work include:

- loads imposed by demolished material that has been dislodged onto the scaffold
- wind forces acting on containment sheeting on the scaffold face
- water retention in containment sheeting by capillary attraction
- progressive removal of building elements affecting the lateral stability of the upper portion of the scaffold

---

<sup>6</sup> Differential deflection occurs when two scaffold planks sag unevenly.

- progressive removal of ties and dismantling of scaffold.

These factors should be considered when using scaffolding for demolition work.

The following control measures should be implemented for scaffolding for demolition work:

- The vertical spacing of scaffold ties may have to be reduced to facilitate the demolition cycle.
- Containment sheeting on the internal face of the scaffold should be installed to deflect any material into the building. This reduces the potential for overloading the scaffold.
- Ensure the scaffold is dismantled progressively and in line with the demolition work.
- Scaffold planks should be secured to prevent dislodgement from falling debris.



## 6. Inspection and maintenance procedures

Procedures should be developed for the inspection and maintenance of scaffolds and scaffolding components to ensure they remain in a safe condition. The inspection of a scaffold on site is particularly important when it is in place for a prolonged period of time.

### 6.1 Frequency of inspection of scaffold

**WHS Regulation section 225(3):** Suspended, cantilevered, spur, hung and other scaffold from which a person or thing can fall more than four metres must be inspected by a competent person before use, before the resumption of use after an incident or repairs, and at least every 30 days.

The required frequency of inspections may vary depending on weather and site conditions, the type and size of the scaffold and the risks associated with scaffold collapse. A scaffold that has been subjected to more heavy-duty workloads (e.g. demolition) should be inspected more regularly. Discuss appropriate intervals for inspection with the supplier when the scaffold is first installed.

The person inspecting the scaffold should be capable of determining areas that have been incorrectly altered and have experience in identifying faults in scaffolds.

Inspection records should be kept on site and include the location, comments, date and time of inspections, the relevant design or specification reference and the person who conducted the inspection. Further information can be found in the *AS/NZS 4576 Guidelines for scaffolding*.

### 6.2 Structural inspection of scaffolding components

**WHS Act section 25:** Suppliers of plant must ensure, so far as is reasonably practicable, that it is without risks to health and safety when used for the purpose for which it was designed or manufactured.

**WHS Regulation section 199:** Suppliers of used plant must ensure, so far as is reasonably practicable, that any faults in the plant are identified and written notice given of the faults and the condition of the plant to whom the plant is being supplied.

**WHS Regulation section 213(1):** The person with management or control of plant at a workplace must ensure that the maintenance, inspection and, if necessary, testing of the plant is carried out by a competent person.

**WHS Regulation section 213(2):** The maintenance, inspection and testing of plant must be carried out in accordance with the manufacturer's recommendations, or if there are no manufacturer's recommendations, in accordance with the recommendations of a competent person. In relation to inspection, if it is not reasonably practicable to do either of these two things, then the plant should be inspected annually.

Procedures for the regular inspection of new and re-used equipment should be developed and implemented to ensure defects and structural damage is detected.

A competent person should thoroughly inspect all scaffolding components to determine their condition prior to erection. The inspection should include the overall condition, the surface

coatings to prevent corrosion, and welding and fabrication issues. PCBUs should refer to manufacturer's specifications for product maintenance, repair and fitness for use information.

It may be more difficult for scaffolders on-site to identify cracking or wearing where scaffolding is painted. It may be necessary to periodically remove the paint from a sample of the scaffolding in order to verify its structural integrity.

## 6.3 Hand over inspections

**WHS Regulation section 225(2):** The person with management or control of a scaffold at a workplace must ensure that the scaffold is not used unless the person receives written confirmation from a competent person that construction of the scaffold has been completed.

The person responsible for the erection or alteration of the scaffold should provide the PCBU or principal contractor with a handover certificate which is kept on site until the scaffold has been dismantled.

For scaffolds under four metres, a handover certificate should state that it has been erected in accordance with the manufacturer's instructions. For scaffolds over four metres see *Appendix 4: Scaffold handover certificate – scaffold over four metres*.

# Appendix 1: Dictionary

**Access platform** – a platform that is only used or intended to be used to provide access for persons, or for persons and materials to or from places of work.

**Advanced scaffolding** means scaffolding work included in the class of Intermediate scaffolding and scaffolding work involving any of the following:

- cantilevered hoists
- hung scaffolds, including scaffolds hung from tubes, wire ropes or chains
- suspended scaffolds.

**Baseplate** – a plate to distribute the load from a load-bearing member to the supporting structure.

**Basic scaffolding** means scaffolding work involving any of the following:

- modular or prefabricated scaffolds
- cantilevered materials hoists with a maximum working load of 500 kg
- ropes
- gin wheels
- safety nets and static lines
- bracket scaffolds (tank and formwork).

but excluding scaffolding work involving equipment, loads or tasks listed under intermediate and advanced scaffolding.

**Bay** – the space enclosed by four adjacent standards, or the equivalent space in a single pole scaffold.

**Brace** – a member fixed diagonally to two or more members of the scaffold to provide rigidity to the scaffold.

**Butt** – a tube fixed to a scaffold and butting to an adjacent structure, to prevent horizontal movement of the scaffold in the direction of the structure.

**Buttress** – a support to the side of a scaffold which provides for an effective increase in the on-ground base width, allowing a greater freestanding height.

**Castor** – a swivelling wheel attached to the lower end of a standard for the purpose of supporting and moving a scaffold.

**Catch platform** means a platform designed to provide overhead protection to persons by catching falling objects.

**Cladding** – common term for the perimeter containment screening or any other material added to the vertical face of the scaffold which will affect the wind and environmental loads on the scaffold.

**Competent person** – in relation to performing a design or inspection or other task for a control measure, is a person who has acquired, through training, qualifications or experience, the following knowledge and skills:

- sound knowledge of relevant Australian Standards, relevant codes of practice and other relevant legislation

- ability to read and interpret drawings
- sound knowledge of, and competence in, the risk management process for the erecting, altering and dismantling of scaffold systems, including:
  - hazard identification and risk assessment
  - measures to control exposure to risks
  - safe work practices and procedures
  - how to plan and prepare scaffolding.

**Counterweight** – a weight or series of weights that counterbalance a scaffold from overturning.

**Cradle** – that portion of the assembly incorporating a suspended platform.

**Detached dwelling** means a residence that is a single detached dwelling or manufactured home as defined in the *Queensland Building and Construction Commission Regulation 2018*.

**Edge protection** means a barrier to prevent a person falling erected along the edge of:

- a building or other structure; or
- an opening in a surface of a building or other structure; or
- a fall arresting platform; or
- the surface from which work is to be done.

**Engineer** – in relation to the performance of a task, means a person who:

- (a) is a registered professional engineer under the *Professional Engineers Act 2002*; and
- (b) is competent to perform the task.

**Guardrail** – a structural member to prevent persons from falling off any platform, walkway, stairway or landing.

**Guy rope** – a rope used to help stabilise a vertical member.

**Intermediate scaffolding** means scaffolding work included in the class of Basic scaffolding and scaffolding work involving any of the following:

- cantilevered crane loading platforms
- cantilevered scaffolds
- spur scaffolds
- barrow ramps and sloping platforms
- scaffolding associated with perimeter safety screens and shutters
- mast climbing work platforms
- tube and coupler scaffolds (including tube and coupler covered ways and gantries).

but excluding scaffolding work involving equipment, loads or tasks listed under advanced scaffolding.

**Internal gap** – the gap between the inner edge of the length of the platform and the face of the building or structure immediately beside the platform.

**Landing** – a level area used to provide access to a stairway or ladder, or located at an intermediate level in a system of stairways or ladders.

**Ledger** – a horizontal structural member longitudinally spanning a scaffold.

**Lift** – the vertical distance from the supporting surface to the lowest ledger or level at which a platform can be constructed, or the vertical distance between adjacent ledgers or levels at which platforms can be constructed.

**Loading bay** – a platform on a scaffold for the storage of materials and equipment.

**Member** – anything that forms part of the scaffold assembly.

**Needle** – a cantilevered structural member that forms part of the scaffold assembly.

**Outrigger** – a framed component that increases the effectiveness of base dimensions of a tower and is attached to the vertical load-bearing members.

**Parapet** – a vertical element usually located at the edge of a balcony, roof, bridge or similar structure.

**Perimeter containment screening** means a screen:

- (a) designed to stop objects falling on persons from a level of a building; or
- (b) to redirect a falling object onto a catch platform.

**Platform** – an elevated surface.

**Platform bracket** – a bracket attached to the scaffold to enable a platform to be placed between the scaffold and the building or structure.

**Putlog** – a horizontal structural member spanning between ledgers or a ledger and an adjacent wall, and intended to support a platform.

**Scaffold** means a temporary structure specifically erected to support access or working platforms.

**Scaffolding work** means erecting, altering or dismantling a temporary structure that is or has been erected to support a platform and from which a person or object could fall more than 4m from the platform or the structure.

**Scaffold plank** – a decking component, other than a prefabricated platform, that is used or intended to be used in construction of any platform supported by a scaffold.

**Soleboard** – a board that is able to distribute the load from a load-bearing member to a supporting surface and is intended for use underneath baseplates.

**Spur** – an inclined load-bearing member that transmits a load to the supporting structure.

**Standard** – a vertical structural member that transmits a load to the supporting structure.

**Static line** means a flexible line, to which a lanyard is attached, supported by at least two anchorage points located so that the angle between the horizontal and an imaginary straight line between any anchorage point and the other or nearest anchorage point is:

- if the manufacturer of the flexible line has specified the size of the angle—not more than the size specified; or
- if the manufacturer has not specified the size of the angle—not more than 5°.

**Strut** – a scaffold member subject to a compressive force.

**Supporting structure** – any structure, structural member or foundation that supports a scaffold.

**Suspension rig** – a supporting structure (including the trolley rack) from which a cradle is suspended.

**Suspension rope** – a rope carrying the weight of a cradle and supporting an imposed load.

**Tie** – a member or assembly of members used to tie a scaffold to a supporting structure.

**Transom** – a horizontal structural member transversely spanning an independent scaffold at the standards.

**TWP** – top working (or catch) platform of a scaffold. Typically used to define the height of the scaffold.

**Working load limit (WLL)** – the maximum working load that may be applied to any component or system.

**Working platform** – a platform from which persons perform work and may also be used to support materials and equipment.

# Appendix 2: Inspection checklist

## 1. Scaffold vicinity

- Has public protection been provided?
- Have sufficient safeguards against electric powerlines been provided?
- Is there sufficient control over vehicle movement?
- Is there sufficient control over crane operation?
- Are there sufficient controls for the storage, handling and use of hazardous chemicals?
- Are scaffolds erected a safe distance away from trenches or excavations?

## 2. Supporting structure

- Is the supporting structure in good condition?
- Does the supporting structure have adequate strength?
- Are there sufficient controls to prevent deterioration of the supporting structure?
- Are all measures to strengthen the supporting structure adequate?
- Is the risk of the supporting structure being overloaded from other sources adequately controlled?
- Is the scaffold built on solid ground? If built on soft ground, are soleboards used to properly distribute the load?

## 3. Soleboards and baseplates

- Are there sufficient soleboards?
- Are the soleboards of suitable material and in a serviceable condition?
- Are the soleboards secure?
- Are there sufficient baseplates?
- Are the baseplates of the appropriate type?
- Are the baseplates serviceable and of suitable dimensions?
- Are the baseplates secure?

## 4. Scaffold structure

- Are the standards bearing firmly?
- Are the standards plumb (or as designed)?
- Are the longitudinal standard spacings correct?
- Are the transverse standard spacings correct?
- Are the joints in standards correctly positioned?
- Are the joints in standards correctly secured (special duty or hung scaffold)?
- Are the ledgers level (or as designed)?
- Are the ledgers continuous (or as designed)?
- Are the lift heights correct?
- Are the horizontal ledger spacings correct?
- Are the ledgers correctly secured?
- Are ledger joints correctly positioned (tube and coupler scaffold)?
- Are the joints in ledgers correctly secured (tube and coupler scaffold)?
- Are there sufficient transoms/putlogs?
- Are the transoms/putlogs correctly positioned and secured?
- Is the bracing adequate?
- Is the scaffold sufficiently stable?

- Are the ties correctly positioned and correctly fixed?

#### **5. Platforms**

- Does the scaffold have the required number of working platforms?
- Are the working platforms at the required locations?
- Are catch platforms correctly positioned?
- Are the platforms and supporting scaffold constructed for the appropriate duty live loads?
- Are the platform dimensions suitable for the intended work?
- Is there adequate edge protection?
- Are the platforms correctly constructed?
- Are planks secured against wind?

#### **6. Access and egress**

- Is there safe access and egress to every scaffold platform?
- Are temporary stairways correctly installed?
- Are portable ladders of an industrial grade, serviceable and correctly installed?
- Are access ways and access platforms correctly installed?

#### **7. Cladding**

- Has the scaffold been designed for wind loading on any cladding?
- Are the fixing ties secure?
- Are there any rips or tears?
- Are the overlap joints satisfactory?

#### **8. General fitness for purpose**

- Is there adequate provision for material handling?
- Are the clearances between the scaffold and adjacent structures correct?
- Is there adequate protection from falling debris?
- Has the scaffold been adequately designed to support all attachments?
- Are all approaches and platforms effectively lit?

#### **9. Mobile scaffolds**

- Is the supporting surface hard and flat?
- Is the area of operation free of floor penetrations, powerlines and other hazards?
- Are the castor wheel locks in working order? They should be locked at all times, except during movement of the scaffold.



# Appendix 3: Published technical standards

## AS 1418.2: Cranes (including hoists and winches) – Serial hoists and winches

This Standard specifies requirements for serial hoists and winches. See Section 5.3.4 *Scaffold hoists* of this code.

## AS/NZS 1576.1: Scaffolding – General requirements

This Standard sets out design and operational requirements for scaffolding, except trestle scaffolding, portable ladders intended to be used as working platforms and elevating working platforms.

## AS/NZS 1576.2: Scaffolding – Couplers and accessories

This Standard specifies requirements for couplers and accessories for light, medium and heavy duty scaffolding, in accordance with AS/NZS 1576.1.

## AS/NZS 1576.3: Scaffolding – Prefabricated and tube-and-coupler scaffolding

This Standard specifies performance requirements for prefabricated and tube-and-coupler scaffolding. It is to be read in conjunction with AS/NZS 1576.1.

## AS/NZS 1576.4: Scaffolding – Suspended scaffolding

This Standard sets out requirements for the materials, and design, of suspended scaffolding including the supporting structure (excluding building maintenance units). It is to be read in conjunction with AS/NZS 1576.1.

## AS/NZS 1576.5: Scaffolding – Prefabricated splitheads and trestles

This Standard specifies requirements for splitheads and trestles that are used as supports for temporary platforms (excluding trestle ladders).

## AS/NZS 1576.6: Scaffolding – Metal tube-and-coupler scaffolding – deemed to comply with AS/NZS 1576.3

This Standard specifies requirements for uncladded metal tube-and-coupler scaffolding that does not exceed 33m in height and is deemed to comply with the performance requirements of AS/NZS 1576.3 for light, medium and heavy duty loads.

## AS/NZS 4576: Guidelines for scaffolding

This Standard gives practical guidance for the training and certification of scaffolders, the preparation of sites for scaffolding, and the safe selection, supply, erection, alteration, dismantling, maintenance, inspection and use of scaffolding and scaffolding equipment.

## AS/NZS 1170.2: Structural design actions – Wind actions

This Standard sets out procedures for determining wind speeds and resulting wind actions to be used in the structural design of structures subjected to wind actions other than those caused by tornadoes.

The Standard covers structures within the following criteria:

- Buildings less than 200m high.
- Structures with roof spans less than 100m.
- Structures other than offshore structures, bridges and transmission towers.

# Appendix 4: Scaffold handover certificate – scaffold over four metres

Scaffold supplier/erector		Client	
Certificate no:		Client name:	
Company name:			
Address:		Address:	
		Site address:	
Contact phone:		Contact phone:	
Fax:		Fax:	
<b>Project details</b>			
Project/reference number:			
Description of area handed over:			
Drawings attached:			
Intended use of scaffold:			
Duty classification:			
Number of working decks:			
TWP height:			
3 m bays:	2.4 m bays:	1.8 m bays:	
1.3 m bays:	0.8 m bays:	Access bays:	
Plant design registration number/s:	Additional details:		
<b>Handover of scaffold</b>			
The scaffold detailed above has been erected in accordance with the attached drawings, Scaffolding Code of Practice, AS/NZS 1576 and AS/NZS 4576 and is suitable for its intended purpose.			
Name:		Signature:	
Certificate no:			
Time:		Date:	
<b>Acceptance – on behalf of the client</b>			
Name:		Signature:	
		Date:	
Arrange for scaffold to be inspected at intervals not exceeding 30 days or immediately following any incident which may affect the adequacy of the scaffold.			

# Appendix 5: Compliance pack for suspended (swing-stage) scaffolds

## **Ensuring safe use of suspended (swing-stage) scaffolds**

Principal contractors, building owners and managers, PCBUs and self-employed persons have a duty to assess and manage the risks of using suspended scaffolds.

Risk assessment and risk management for suspended scaffolds includes:

### **1. Design and engineering**

All components of the suspension rig should be designed and documented by a qualified and suitably experienced engineer.

All areas of design for a suspended scaffolding system need to receive a formal sign-off from a qualified and suitably experienced engineer. The formal sign-off for the swing-stage system is to include the needle suspension system, cradle, and hoist. Certification of the different components can be provided by different parties.

Prior to being set up, engineering verification of the structural adequacy of the suspension system and the cradle is to be obtained. The manufacturers of the cradle and hoist are to provide the structural verification and information on the maximum working load limit (WLL). The suspension and supporting structures are to be designed and verified by a suitably qualified engineer.

### **2. Loading**

The WLL is to be clearly marked on the cradle of the suspended scaffold. The WLL of a cradle will depend on factors such as its length, type of construction and material type. Materials loaded into the cradle should be evenly distributed and not be concentrated in one area.

To prevent overloading, swing-stage operators should verify the mass of the load to be included in the cradle.

### **3. Load-limiting devices**

*AS/NZS 1576.4 Scaffolding – Suspended scaffolding* specifies electric scaffold hoists shall have a device to limit the lifting capacity of the hoist to a maximum of 1.25 times the rating of the hoist. Whatever the hoist stall capacity is, the suspension system and the cradle are to be designed to withstand the stalling load applied by all scaffold hoists in use. This feature prevents failure in the event of the cradle snagging on an obstruction.

### **4. Installation**

At the first installation of a swing-stage scaffold system, a competent person (who should be a qualified, experienced engineer) must provide verification that the swing-stage scaffold system has been installed safely. Persons holding an advanced scaffolding or rigging high risk work licence under the national certification system must be engaged to install suspended scaffolds.

On subsequent moves and reinstallation of the swing-stage scaffold system on that project, the reinstallation must be reinspected and verified. If the reinstallation is different to that which was originally verified by the engineer, other than a smaller outboard, smaller cradle or larger inboard, a competent person (who should be a qualified, experienced engineer)

must approve the new installation. If the reinstallation is set-up as per the approved system originally verified, then a competent person (other than an engineer) can check and verify the system's set-up.

A competent person, for this activity, means a person who meets the criteria outlined in the *Competent person benchmarks for swing-stage set-up verification*. The competent person and their PCBU should sign this form to verify the competent person's statement of competency.

The competent person should also complete a *Swing-stage suspension system verification statement*.

## **5. Inspection**

Inspections to provide verification are to be carried out as outlined in previous sections. In addition, swing-stage components are to be inspected for damage, wear and cracks before use and at pre-determined intervals. Some cracks may not normally be visible to the eye. Non-destructive testing is to be performed to check for cracks in high stress areas.

## **6. Fall-arrest systems**

Persons located in swing-stage cradles are to wear fall-arrest harnesses attached to a properly designed anchorage system. A travel restraint system, where a fall is not possible, attached to a static line in the cradle may be used. A thorough assessment needs to be undertaken to ensure appropriate control measures are in place to address any secondary risks that might arise.

Fall-arrest systems must comply with the WHS Regulation and should be designed by a competent person. Guidance on the design of fall arrest systems is also provided in *AS/NZS 1891 – Industrial fall-arrest systems and devices*.

## **7. Public protection**

Where work is carried out above or in the vicinity of pedestrian or vehicular access, adequate protection (such as hoarding and other falling object restriction devices) should be used to minimise the risk to the public, and area lost to public access. Further requirements are listed in the WHS Act and WHS Regulation.

## **8. Training and competence**

A principal contractor should ensure a person is competent, trained and has had a site-specific swing-stage induction before that person begins using the swing-stage. The swing-stage induction needs to address safe operation of the swing-stage scaffold. The principal contractor should make a record of the people inducted and the date it was given. The record should be kept for the duration of the construction work.

A person installing (erecting, altering or dismantling) a suspended scaffold must have an advanced scaffolding or rigging high risk work licence, and must be competent in the installation of suspended scaffolds. A person who has successfully completed the *CPCCLSF4001A – Licence to erect, alter and dismantle scaffolding advanced level* course (or any subsequent, equivalent course) is generally considered to have the required competence. A person using a suspended scaffold should undertake a *Course in the Safe Use of Swing Stage Scaffolds* or a subsequent, equivalent course.

# Swing-stage advice

## A5.1 Equipment supply advice

Suppliers should obtain and keep written confirmation that:

- The suspended scaffolding system has been designed in accordance with AS/NZS 1576.1 and AS/NZS 1576.4.
- Couplers supplied for use with suspended scaffolding have been designed, tested and marked in accordance with AS/NZS 1576.2.
- Scaffolding hoists have been designed, manufactured and tested in accordance with AS 1418.2.

In particular, suppliers should ensure that:

**A5.1.1** The design of the powered scaffolding hoists being supplied are a twin rope type.

**A5.1.2** All scaffolding hoists and secondary protective devices should have legible data plates bearing the following information:

- Type model identification
- Serial number
- Details of steel wire rope used with the hoist – nominal size, grade (quality), construction, and maximum length (where applicable)
- Rated capacity hoisting
- Name or identification mark of the manufacturer of the hoist
- Reeving requirements, where applicable
- Power supply requirements, where applicable.

**A5.1.3** The Residual Current Device (RCD) for the cradle, should have a legible data label bearing the following information:

- Rating load in Amps
- Residual tripping current (not exceeding 30 mA)
- Power supply in Volts.

**A5.1.4** All hoisting controls should be labelled and, unless the function is obvious, the operational functions displayed. All switches should be of the spring loaded/deadman type, that returns to safe operation. See AS/NZS 4576 for further advice. Labels should include:

- operation instructions
- emergency stop switch
- up and down control.

**A5.1.5** The control box should be compatible with the operation of the specific type and model of hoist and, if multiple hoists are used, each hoist should have the same operating specifications.

**A5.1.6** The control box should be removable, unless an alternative method is used to isolate power to the cradle, for safety and security when the suspended scaffold is not in service.

**A5.1.7** Before each site delivery, each scaffolding hoist, each secondary protective device and each load-limiting device should have been inspected and subjected to an operational test in accordance with the recommendations given in AS/NZS 4576.

- Undergo inspection and testing
- If an electrically powered scaffolding hoist, be fitted with a load-limiting device that will prevent the hoist from lifting more than 125 per cent of its rated load
- If a secondary protective device, be capable of preventing the cradle from falling due to a failure within the hoist.

**A5.1.8** Between each hiring of scaffolding equipment the supplier should ensure that all scaffolding components are inspected and maintained.

**A5.1.9** The supplier of the suspended scaffold should provide the users of the equipment with written operating and safe use instructions and the daily safety checklists.

## A5.2 Scaffold environment advice

**Scaffold erectors and operators need to take into consideration the areas around the suspended scaffold during design, erection and operation. The following particular areas of concern should be considered and addressed prior to work commencing on the erection or operation of the scaffold.**

**A5.2.1** Where the scaffold is erected adjacent or over public space or adjoining property, there may be the need to provide specific controls (e.g. hoardings, catch platforms, barricades.)

**A5.2.2** Where the possibility exists for other workers to enter the area below the suspended scaffold, specific controls may need to be provided (e.g. catch platforms, barricades, signs).

**A5.2.3** Powerlines are a major hazard and no part of the suspended scaffold including suspension and secondary ropes, which should be anchored, can enter the exclusion zone for that powerline. See Section 3.1 *Working near energised overhead electric lines* of this code for more information.

**A5.2.4** All powerlines should be considered live unless there is written confirmation from the local distribution company that the powerlines are not live at the specific time that work is being undertaken.

**A5.2.5** Uncontrolled vehicle movement in close proximity to a suspended scaffold (collision), the trailing power cable or hoisting cables (entanglement) may lead to structural collapse, uncontrolled movement of the platform or mechanical damage. Protective measures may need to be provided to control the movement of vehicles.

**A5.2.6** Where cranes operate in close proximity to a suspended scaffold, there is a risk of the load snagging the scaffold or endangering persons on the platform. Specific site procedures may need to be developed to minimise the risk.

**A5.2.7** Where corrosive substances are to be used on the scaffold or in its vicinity, it may be necessary to develop specific procedures to minimise the risk of damage to critical scaffolding components.

**A5.2.8** The use of certain types of equipment in some areas may place persons at high risk. The dangers presented by hazardous areas should be assessed before selecting equipment (e.g. electric hoists should not be used where dust can form an explosive atmosphere).

## A5.3 Installation design advice

**The principal contractor or body corporate needs to ensure that any scaffolding configuration which they design, modify or allow to be modified is suitable for the location and the intended use of the equipment. The designer of the scaffold should consider the following to ensure that during erection and when properly used it is not unsafe and a risk to health.**

**A5.3.1** The building or structure to which the suspended scaffold is to be mounted should be capable of supporting the scaffold and all intended loads (dead, live and environmental loads). The supporting structure needs to be assessed by an engineer and a statement of assessment provided.

**A5.3.2** A detailed design plan should be prepared for the erection of each suspended scaffold, which takes into account the design specifications of the scaffold, the limitations of the support structure, and maximum operational wind speed or lateral forces it may be exposed to during erection or operation.

**A5.3.3** Where structural alterations to the suspended scaffold are made, the changes should be recorded on an amended design plan. The designer or another competent person must review and approve the changes before the scaffold is used for the first time.

**A5.3.4** Damage can be caused to the cradle or hoisting systems if certain activities are undertaken without adequate protective measures being in place (e.g. welding, water or pressure blasting, demolition activities, etc).

**A5.3.5** To operate correctly, an adequate power supply should be available for electrically powered hoists to ensure that the voltage drop does not exceed 5 per cent of the nominal supply voltage. The flexible cord for the suspended scaffold is only part of this 5 per cent. Additional information on the electrical requirements is provided in A5.5.

**A5.3.6** Lateral restraints should be used to prevent instability of the platform which may result from the work procedures or wind, and may include:

- lanyards
- tensioned wire ropes
- removable ties
- fan units
- suction units.

Ensure all restraints are removed when no longer required.

## A5.4 Scaffold erection advice

**The scaffold erector needs to ensure that nothing about the way in which the suspended scaffold is erected is unsafe or a risk to the health of the scaffolder(s) or others and when installed and properly used is not unsafe or a risk to the health of the operators or others.**

**A5.4.1** The person carrying out or directly supervising the erection, dismantling or modification work on any suspended scaffold must have either an advanced rigging or scaffolding high risk work licence.

**A5.4.2** The person supervising the work should have a copy of the design plan, which specifies the rigging requirements including the number, size and positioning of the counterweights, prior to the erection or modification of the suspended scaffold.

**A5.4.3** Ensure that fall protection is in position at the building edge or the scaffolders are using safety harnesses with adequate anchorage points if working near an exposed edge.

**A5.4.4** To prevent injury to workers the area around the support rig should be restricted to only those workers engaged in assembling the scaffold.

**A5.4.5** To prevent injury to persons, from dropped cables, rigging components or tools, a sufficiently large area below the scaffold should be barricaded off to prevent access.

**A5.4.6** During erection, where there is no physical barrier at the edge to prevent objects falling off the supporting structure or when work is occurring over the edge, a safety observer should be positioned, if necessary, to prevent people accessing the barricaded area below the scaffold.

**A5.4.7** Any counterweight should be manufactured for that purpose, labelled with its mass in kilograms, be placed directly on the needle or innermost support in the designed location, and secured by a keyed lock.

**A5.4.8** When used, traversing tracks should be fitted with through-bolted stops at the ends, to prevent any trolley from running off, and each trolley should have a rated working load of at least 1000 kg.

**A5.4.9** The outboard end of a needle should never be lower than the inboard end.

**A5.4.10** The suspension rig should form a structure that is rigid and stable under working conditions.

**A5.4.11** Only the wire rope recommended by the manufacturer for the hoist shall be used; details of the wire rope construction can be located on the hoist data plate. The use of the wrong construction of wire rope in a scaffold hoist has resulted in sudden failure, with the rope severing in the hoist.

**A5.4.12** A secondary protective device shall be provided for each scaffolding hoist, to operate on a secondary wire rope. This device provides an emergency brake to hold the cradle if the hoist or wire rope within the hoist fails; some types may also prevent an over-speed decent.

**A5.4.13** It is essential that the secondary protective device's internal mechanism is adjusted for the size of wire rope fitted, as some devices are capable of using different sizes of wire rope.

**A5.4.14** The secondary wire rope for any scaffolding hoist should be attached to the suspension rigging, at a point that is independent of the main suspension rope attachment. Two thimbles are to be used, not one with an over-rated shackle connected to two smaller shackles.

**A5.4.15** All cradle components should be inspected, on site, prior to assembly and checked to ensure all locating pins and clips are fitted and in position.

**A5.4.16** A sign, clearly displaying the safe working load limit, in kilograms, should be fixed to the inside of each cradle.

**A5.4.17** The cradle should have guardrails, midrails and toe boards fitted. The working deck needs to be fixed, of a non-slip type and with adequate drainage holes. None of these components should have visible signs of mechanical damage (cracked or split welds, missing or broken decking, cut or bent guardrails, etc).

**A5.4.18** The finished suspended scaffold should conform to the design plan. Alterations due to installation conditions should be included on an amended plan. The designer or another competent person should review these variations and approve the modified plan before the scaffold is first used.

**A5.4.19** A competent person must supply a written statement that the scaffold is complete and safe for use before the scaffold is used for the first time and after every alteration.

## A5.5 Electrical installation advice

**It is essential for safe operation of the suspended scaffold hoists and electrical protection devices to have an adequate power supply. The principal, electrical and scaffolding contractors should coordinate on the planning of the electrical installation to ensure appropriate voltage levels are provided.**

**A5.5.1** This may include positioning the power-board close to the scaffold, dedicated power circuits, larger sub-mains, alternative methods of positioning the power-board, etc.

**A5.5.2** To limit voltage drop, the suspended flexible cord should:

- not be of excessive length, or
- if extra length is required, have larger size conductors to compensate.

**A5.5.3** The power supply for the suspended scaffold may need to be close to the scaffold to limit the length of the flexible cord needed to descend to the platform; this will assist in limiting voltage drop.

**A5.5.4** The construction power-board should be designed so the removal of the suspension flexible cord from the socket-outlet requires a person to complete a deliberate act.



**A5.5.5** The suspended flexible cord should be supported in a manner that protects the cable from mechanical damage and prevents the cable from bending at a radius less than the manufacturer's minimum.

**A5.5.6** Any suspended flexible cord shall be the heavy-duty double insulated type and be able to support its own weight over the length of the drop. Electrical cable should be fitted with thimble and eye for suspension to stop damage to cable.

**A5.5.7** The flexible cord should be supported in such a manner as to prevent the cradle from fouling or causing mechanical damage to the cable. The cable should be installed so that it is not pulled across the structure of the cradle.

**A5.5.8** The flexible cord should be long enough to allow the cradle to descend to the ground or a lower structure, for egress, in an emergency.

**A5.5.9** When in use the control box should preferably be attached to the guardrail of the cradle on the side away from the working face.

**A5.5.10** The electrical cables installed in the cradle should not be excessive in length, to prevent mechanical damage occurring to the cables and to limit voltage drop.

**A5.5.11** Electrical cables from the control box to the hoists should be enclosed for protection from mechanical damage and securely attached to cradle. Additional mechanical protection may be required and is dependent on the work undertaken (e.g. demolition, grinding, abrasive blasting, etc).

**A5.5.12** There should be a system that allows the suspended scaffold to be effectively isolated from the power supply when not in use, to prevent unauthorised operation; this may be located within a locked power board or by the use of a readily removable control panel on the cradle.

## A5.6 Scaffold operation advice

**The PCBU of persons working in the suspended scaffold, prior to operating the equipment, should have procedures and safe systems of work in place to ensure that the equipment is not unsafe when properly used and persons are not exposed to risks to health.**

**A5.6.1** A written statement that the scaffold is complete and safe for use must be supplied by a competent person prior to operating the scaffold.

**A5.6.2** The supplier of the suspended scaffold should provide the users of the equipment with written operating and safe use instructions and daily safety checklists.

**A5.6.3** The people suspended on the platform must have a method of safe egress; procedures should be in place for the rapid retrieval of the suspended people in the event of an emergency. This could be an onsite crane work box or other method. It is not sufficient to rely on the local fire and rescue service.

**A5.6.4** The danger of debris, from higher work, falling onto workers in the cradle may exist and measures may need to be in place to control this risk.

**A5.6.5** The PCBU should nominate the designated operators and provide written authorisation.

**A5.6.6** The PCBU should provide operators with information, training and instruction on the specific type of equipment to enable them to carry out the daily inspections and to use the equipment safely.

**A5.6.7** The PCBU should ensure workers are trained in the safe work practices for suspended scaffolds, including any emergency procedures. Workers should be able to demonstrate these safe work practices before working in the suspended scaffold.

**A5.6.8** The PCBU should maintain, and have available, up-to-date records of this training.

**A5.6.9** Effective communications should be in place between the cradle or chair and other workers to alert others on site in case of an emergency. It may include people onsite being in sight of the cradle/chair at all times to observe hand signals, hear whistles, bells or in radio or telephone communication.

**A5.6.10** Where access and egress is not from the ground or a protected landing, safety harnesses and lanyards shall be provided and used when entering or leaving the cradle. During this procedure, safety harnesses shall be attached to suitable anchorage points on the main structure. The cradle should also be effectively secured to prevent movement.

**A5.6.11** If the scaffold is subjected to movement due to wind forces or the work procedures being undertaken, lateral restraints are required.

**A5.6.12** The cradle platform should be in a tidy condition with unobstructed access along the entire length.

**A5.6.13** The total load of all persons, materials, and equipment should not exceed the safe working load limit of the suspended scaffold.

**A5.6.14** During meal breaks etc, the platform may be secured to the structure, to prevent damage due to wind. The power should be disconnected from the scaffold hoists, supply point or control board.

**A5.6.15** Overnight or longer periods require the platform to be parked in its storage position and secured to the structure to prevent movement or damage due to wind. Where not on a secured site, it should be parked in an inaccessible position. All trailing ropes and cables to be securely stored, protective devices locked onto ropes, power cables disconnected from supply and if there are air operated air lines these should be disconnected and pressure released.

**A5.6.16** Each day, prior to commencing work from the scaffold, the operator should carry out a safety inspection and complete the daily log-in sheet, in line with the requirements of the supplier.

**A5.6.17** A competent person should inspect the cradle and suspension system at not greater than monthly intervals, if the scaffold has been onsite and not altered during that time.

**A5.6.18** All portable electrical equipment including scaffolding hoists and cabling is required to be inspected and tested every three months, while the RCD protection devices are to be time/current tested monthly.

## **A5.7 Boatswain's chair operation advice**

**When boatswain's chairs are used, the following issues also need to be addressed.**

**A5.7.1** Unless a large enough exclusion zone is setup under the chair to protect other persons, measures should be in place to prevent tools or equipment falling from the chair (e.g. lanyards for hand tools, heavy equipment suspended from another rope, etc).

**A5.7.2** The operator should be able to activate all controls including the emergency descent system from the seated position.

**A5.7.3** If the chair is subjected to movement due to wind forces or the work procedures being undertaken, lateral restraints are required.

# PCBU checklists

## A5.8 Swing-stage scaffold supplier checklist

Part	Scaffold suppliers – pre-delivery of equipment	yes / n/a / no
A5.1.1	Are the powered scaffolding hoists twin rope type?	
A5.1.2	Do scaffolding hoists and the secondary protective devices have legible data plates bearing the necessary information?	
A5.1.3	Does the RCD in the cradle have a legible data label bearing the necessary information?	
A5.1.4	Do the controls have all necessary labels and operational functions displayed?	
A5.1.5	Are the hoist(s) and the central control box compatible?	
A5.1.6	Is the control box designed to be removed from the platform when not in use?	
A5.5.6 A5.5.8	Has the correct type, size and length of flexible power cord been provided?	
A5.4.11	Is the correct size and type of wire rope provided?	
A5.4.13	If required, has the secondary protective device been adjusted for the size of wire rope to be used?	
A5.1.7	Has each hoist and secondary protective device undergone inspection and load testing before being installed onsite?	
A5.1.8	Have all scaffolding components been inspected before being sent to site?	
A5.4.7	Are the counterweights specifically manufactured for the purpose and correctly labelled?	
A5.3.2	Are the supplied components compatible with the design plan?	
A5.1.9	Have all relevant safe use instructions and checklists been provided to the user?	

This checklist is designed to be used with the *Compliance Pack for suspended (swing-stage) scaffolds*, sections of which are referenced by the number in the left column of the checklist. Unless **yes** or **n/a** is recorded the scaffold should not be used, until rectification occurs.

## A5.9 Swing-stage scaffold principal contractor / body corporate checklist

Part	Scaffold design engineer	yes / n/a / no
A5.3.1	Has the supporting structure been assessed by an engineer?	
A5.3.1	Has a statement of assessment for the supporting structure been provided to the site?	
A5.3.2	Has a detailed design plan been prepared for the erection of the scaffold?	
A5.3.3	Have alterations or changes to the scaffold been amended to the design plan?	
A5.3.4 A5.2.7	Has the tasks which are to be carried out from the scaffold been taken into consideration when selecting and designing the scaffold?	
A5.2.1	Has the protection of the public been addressed?	
A5.2.2	Has the protection of other workers been addressed?	
A5.4.3	Has the protection of workers, who have to erect the scaffold been addressed?	
A5.2.3	Has the issue of the proximity to overhead power-lines been addressed?	
A5.2.5	Has the issue of vehicle traffic around the scaffold been addressed?	
A5.3.5	Has the voltage drop (electrical power) limitations of the installation been taken into consideration?	
A5.3.6	Have measures to restrict lateral movement of the scaffold, during operation, been addressed?	
A5.6.10	Have issues relating to safe access and egress of the workers, who are to use the platform, been addressed?	
A5.6.14 A5.6.15	Has the storage and security of the scaffold, when not in use, been addressed?	

This checklist is designed to be used with the *Compliance pack for suspended (swing-stage) scaffolds*, sections of which are referenced by the number in the left column of the checklist. Unless **yes** or **n/a** is recorded the scaffold should not be used, until rectification occurs.

### A5.10 Swing-stage scaffold erection and installation checklist

Part	Scaffold erection and installation	yes / n/a / no
A5.4.1	Is the erection, alteration or dismantling of the scaffold carried out or directly supervised by the appropriate certificate holder?	
A5.3.1	Has the supporting structure been assessed by a competent person?	
A5.3.1	Has a statement of assessment for the supporting structure been provided to the site?	
A5.4.2	Does the scaffold erector have a copy of the scaffold design plan, prior to erection?	
A5.4.3	Do the scaffolders erecting the scaffold have adequate fall protection?	
A5.2.1	Has the protection of the public been addressed?	
A5.2.2	Has the protection of other workers been addressed?	
A5.2.3	Has the issue of the proximity to overhead powerlines been addressed?	
A5.4.5	During the erection, <b>if needed</b> , are the areas around the support rigging, underneath and adjacent to the cradle barricaded off?	
A5.4.6	During erection, <b>if needed</b> , is a safety observer positioned to prevent access to the area below the scaffold?	
A5.4.7	Are the supplied counterweights labelled with their weight in kilograms and have they been manufactured for the purpose?	
A5.4.7	Are the counterweights correctly and securely attached to the suspended scaffold support rigging?	
A5.4.8	If used, are traversing tracks fitted with stops at each end of the rails?	
A5.4.8	If used, are traversing trolleys rated at least to the WLL of the system?	
A5.4.9	Are the outboard ends of the needles higher than the inboard ends?	
A5.4.10	Is the suspension rig stable?	
A5.4.11	Is the wire rope used of the correct size and type for the hoist?	
A5.4.12	Is each hoist fitted with a secondary protective device?	
A5.4.13	Has the secondary protective device been adjusted for the size of wire rope fitted?	
A5.4.14	Are all wire ropes independently attached to the rigging?	
A5.4.15	Has the suspended cradle been assembled correctly?	
A5.4.16	Is the safe working load limit displayed in the cradle?	
A5.4.17	Is the cradle in good mechanical condition?	
A5.4.18	Has the scaffold been erected as per the design plan?	
A5.6.10	Has safe access been provided for workers to enter and leave the cradle?	
A5.4.18	Has the scaffold been erected as per the design plan, with any modifications or changes approved and recorded on an amended plan?	

This checklist is designed to be used with the *Compliance pack for suspended (swing-stage) scaffolds*, sections of which are referenced by the number in the left column of the checklist. Unless **yes** or **n/a** is recorded the scaffold should not be used, until rectification occurs.

### A5.11 Swing-stage scaffold electrical installation checklist

Part	Electrical installation	yes / n/a / no
A5.5.1	Has an adequate power supply been provided for the suspended scaffold?	
A5.5.2	Has the voltage drop requirements for suspended flexible cable been taken into consideration?	
A5.5.3	Is the construction power board situated near the support rigging of the suspended scaffold?	
A5.5.4	Can the suspended flexible cable be accidentally removed from power board?	

<b>A5.5.5</b>	Has the suspended flexible cable been correctly secured to the support rigging and the cradle?	
<b>A5.5.6</b>	Is the suspended flexible cord the correct type?	
<b>A5.5.7</b>	Has the suspended cable adequate running clearance?	
<b>A5.5.8</b>	Is the suspended cable of sufficient length?	
<b>A5.5.9</b>	Is the control box attached to the outside guardrail?	
<b>A5.5.10</b>	Are the electrical cables from the control box to each hoist, correctly installed?	
<b>A5.5.11</b>	Are the cables from the control box to each hoist adequately protected from mechanical damage?	
<b>A5.5.12</b>	Are there rain hoods?	

This checklist is designed to be used with the *Compliance pack for suspended (swing-stage) scaffolds*, sections of which are referenced by the number in the left column of the checklist. Unless **yes** or **n/a** is recorded the scaffold should not be used, until rectification occurs.

### A5.12 Swing-stage scaffold handover checklist

<b>Part</b>	<b>Handover of scaffold</b>	<b>yes / n/a / no</b>
<b>A5.4.18</b>	Has the completed or altered scaffold been inspected before being used for the first time?	
<b>A5.4.19</b>	Has a written statement of completion been supplied?	
<b>A5.4.19</b>	Has the user of the scaffold been supplied with all safe use information?	
	Has the <i>Principal contractor or building owner swing-stage statement</i> been completed?	
	Has the <i>Competent person benchmarks for swing-stage set-up verification</i> been completed?	
	Has the <i>Swing-stage suspension system verification statement</i> been completed?	

This checklist is designed to be used with the *Compliance pack for suspended (swing-stage) scaffolds*, sections of which are referenced by the number in the left column of the checklist. Unless **yes** or **n/a** is recorded the scaffold should not be used, until rectification occurs.

### A5.13 Swing-stage scaffold and boatswain's chair operation checklist

<b>Part</b>	<b>Operation</b>	<b>yes / n/a / no</b>
<b>A5.3.1</b>	Has the supporting structure been assessed by a competent person and a statement of assessment for the supporting structure been provided to the site?	
<b>A5.4.19</b>	Has the completed or altered scaffold been inspected before being used for the first time and a written statement of completion been supplied?	
<b>A5.4.18</b>	Has the scaffold been erected as per the design plan?	
<b>A5.6.3</b>	Are emergency rescue procedures in place to remove trapped worker(s)?	
<b>A5.2.1</b>	Has sufficient protection been provided for the public?	
<b>A5.2.2</b>	Has sufficient protection been provided for other workers?	
<b>A5.6.4</b>	Are measures in place to protect the worker(s) on the suspended scaffold from falling debris?	
<b>A5.6.2</b>	Has the supplier provided a copy of the operator's manual and copies of the daily checklist?	
<b>A5.6.5</b>	Are the operators authorised by their PCBU to operate the scaffolding hoist?	
<b>A5.6.6</b> <b>A5.6.8</b>	Have the operators received instruction on the operation of the equipment?	
<b>A5.6.7</b> <b>A5.6.8</b>	Have all persons working in the suspended scaffold received instruction in the safe systems of work and the emergency procedures for the equipment?	
<b>A5.2.3</b> <b>A5.2.4</b>	Have the dangers of overhead electric powerlines been addressed?	

<b>A5.4.6</b>	Are the supplied counterweights adequate for the purpose, of the correct number and are securely attached to the suspension support rigging?	
<b>A5.4.10</b>	Is the suspension rigging stable?	
<b>A5.4.11</b>	Is the wire rope used of the correct construction and size for the hoist?	
<b>A5.4.12</b>	Is each hoist fitted with a secondary protective device?	
<b>A5.4.13</b>	Has the secondary protective device been adjusted for the size of wire rope fitted?	
<b>A5.4.14</b>	Are all wire ropes independently attached to the support rigging?	
<b>A5.4.15</b>	Has the cradle or chair been assembled correctly?	
<b>A5.4.16</b>	Does the cradle or chair appear to be in good mechanical condition?	
<b>A5.4.16</b>	Is a sign with the safe working load in kilograms fixed inside the cradle or to the chair?	
<b>A5.6.13</b>	Is the load on the platform within its safe working load?	
<b>A5.6.10</b>	Is safe access provided for workers to enter and leave the cradle?	
<b>A5.6.11</b>	If required, are lateral restraints being used?	
<b>A5.6.12</b>	Is there safe access along the entire work platform of the cradle?	
<b>A5.2.5</b>	Is there sufficient control over the movement of vehicles in the area of the scaffold?	
<b>A5.2.6</b>	Is there sufficient control of cranes working in the vicinity?	
<b>A5.2.7</b>	Are there sufficient controls over the storage, handling, and use of hazardous chemicals on the cradle?	
<b>A5.2.8</b>	Is the selection of the type of scaffold hoist appropriate for the location?	
<b>A5.6.9</b>	Is there an effective method of communication between the occupants of the work platform and the ground?	
<b>A5.5.6</b> <b>A5.5.7</b>	Has the correct type and size of suspended flexible electrical power cord been provided?	
<b>A5.5.8</b>	Is the suspended flexible electrical cable of sufficient length?	
<b>Part</b>	<b>Operation – Boatswain’s chair</b>	<b>yes / n/a / no</b>
<b>A5.5.4</b>	Is the suspended flexible cable installed so that it cannot be accidentally removed from the power-board?	
<b>A5.5.5</b>	Has the suspended flexible cable been correctly secured to the support rigging and the cradle?	
<b>A5.5.7</b>	Has the suspended flexible cable adequate running clearance?	
<b>A5.5.9</b>	Is the control box attached to the outside guardrail?	
<b>A5.5.10</b> <b>A5.5.11</b>	Are the electrical cables from the control box to each hoist, correctly installed and are the cables protected from mechanical damage?	

This checklist is designed to be used with the *Compliance pack for suspended (swing-stage) scaffolds*, sections of which are referenced by the number in the left column of the checklist. Unless **yes** or **n/a** is recorded the scaffold should not be used, until rectification occurs.

### A5.14 Unattended swing-stage scaffold checklist

<b>Part</b>	<b>Unattended scaffolds</b>	<b>yes / n/a / no</b>
<b>5.14</b>	When the scaffold is unattended for short periods, are appropriate safety measures observed?	
<b>5.15</b>	When left unattended for longer periods, are appropriate safety measures observed?	

This checklist is designed to be used with the *Compliance pack for suspended (swing-stage) scaffolds*, sections of which are referenced by the number in the left column of the checklist. Unless **yes** or **n/a** is recorded the scaffold should not be used, until rectification occurs.

### A5.15 Inspection, servicing and maintenance checklist

<b>Part</b>	<b>Inspection, servicing and maintenance</b>	<b>yes / n/a / no</b>
<b>5.16</b>	Have the operator(s) prior to using the scaffold, been completing the daily checklist?	
<b>5.17</b>	Has the scaffold undergone the monthly inspection?	

<b>5.18</b>	Have all the electrical leads, components, and electrical protection devices been inspected and tested (as per Industry Standard for Electrical Installations on Construction Sites)?	
-------------	---	--

This checklist is designed to be used with the *Compliance pack for suspended (swing-stage) scaffolds*, sections of which are referenced by the number in the left column of the checklist. Unless **yes** or **n/a** is recorded the scaffold should not be used, until rectification occurs.

## Verification forms

The principal contractor, building owner, or representative of the building owner/principal contractor is to sight all the relevant documentation as per the *Principal contractor or building owner swing-stage statement*. The documents to be kept on site, specific to swing-stage installation and operation, are:

- engineer's drawing for the swing-stage suspension system
- engineer's design certification letter for the design of the swing-stage
- competent person's written confirmation that the swing-stage has been erected in accordance with the design documentation for the initial set-up of the swing-stage at this location (including a load test)
- engineer's certification letter to verify the supporting structure is adequate to support a swing-stage suspension system
- advanced scaffolding or advanced rigging high risk work licence of person erecting swing-stage suspension system
- signed *Principal contractor or building owner swing-stage statement*
- signed *Competent person benchmarks for swing-stage set-up verification*
- competent person's *Swing-stage suspension system verification statement* completed and signed, including load testing.

# Principal contractor or building owner swing-stage statement

**Note:** This statement is to be completed by the principal contractor (or a nominated representative of the principal contractor) or the building owner (or a nominated representative of the building owner if a principal contractor does not exist). This statement declares that the representative has sighted the documentation referred to. **It is not an approval of the swing-stage.**

Swing-stage supplier:	Phone number:
Swing-stage installer:	Phone number:
Address where swing-stage is being used:	
Swing-stage identification no.: (if more than one swing-stage on site)	

Document description	Document sighted (tick)
1. Engineer's drawing for the swing-stage suspension system.	
2. Engineer's design certification letter for the design of the swing-stage.	
3. Engineer's verification statement that the swing-stage has been erected in accordance with the design documentation for the <b>initial set-up of</b> the swing-stage at this location. This is to include a load test.	
4. Engineer's certification letter to verify supporting structure is adequate to support swing-stage suspension system.	
5. <i>Advanced scaffolding or rigging high risk work licence</i> of person erecting swing-stage suspension system.	
6. Signed <i>Competent person benchmarks for swing-stage set-up verification</i> .	
7. Competent person's <i>Swing-stage suspension system verification statement</i> completed and signed, including load testing, for re-location of the system (not the initial set-up).	

Principal contractor or building owner statement	
I have sighted the documentation listed above (numbered 1 to 7) that relate to the installation and use of the swing-stage referred to on this statement.	
Name:	Signature and date:
Title:	



# Competent person benchmarks for swing-stage set-up verification

## Verification benchmarks for swing-stage set up

The following benchmarks are the minimum requirements for competent persons to verify that swing-stage installations comply with the engineer's specifications, **other than** for the initial verification.

The benchmarks apply to persons who verify that the engineering specifications for the swing-stage installation have been complied with at each movement of the swing-stage on site. The initial verification, when the swing-stage is set up for the first time on site, is to be provided by the engineer.

The competent person is not required to make engineering decisions such as calculations. Instead, he or she is to verify that the engineer's design specifications, as depicted on the swing-stage drawings, have been complied with.

## Benchmarks

Workplace Health and Safety Queensland (WHSQ) requires the competent person to meet the following benchmarks to verify the engineer's design has been complied with. The competent person is to:

1. Be a holder of an advanced scaffolding or rigging high risk work licence recognised by WHSQ.
2. Have a demonstrated ability to be able to read and interpret technical drawings that relate to the swing-stage installation. This includes the ability to accurately understand and interpret the following:
  - dimensions
  - drawing notes
  - drawing identification and the revision process
  - structural member specifications
  - connection details
  - any special conditions nominated on the drawing
  - when a drawing has insufficient information or detail to be used (i.e. the drawing fails to mention key information and cannot be accurately followed).
3. Have a sound understanding of the current Queensland *Scaffolding Code of Practice* and *AS/NZS 1576.4 Scaffolding - Suspended scaffolding*.
4. Have a minimum of two years' experience associated with the use and inspection of swing-stage scaffolds.
5. Have a sound and accurate understanding of relevant benchmarks for the inspection and discard of scaffolding components, lifting gear, steel wire ropes, scaffold hoists and personal fall arrest equipment. Typical examples include the following:
  - Correct inspection techniques for steel wire rope as detailed in AS 2759 Steel wire rope – Use, operation and maintenance and the associated criteria used for discarding the rope. This includes the correct interpretation of broken wires, broken strands, kinks, and any other wear or abnormalities specified in the Standard.
  - Scaffold and other structural components that are bent, have cracked welds, or rust (other than surface rust), are to be removed from service and discarded. Scaffolding couplers with bent pins, damaged threads and cracked fittings are not to be used.
  - Scaffolding components from different manufacturers cannot be used together unless specifically approved for this application by an engineer or the scaffolding

manufacturer for the specific application in which the scaffolding is being used. In other words, no “mixing” of scaffolding components.

- Scaffolding components manufactured from different materials (i.e. aluminium and steel) cannot be used together on the swing-stage installation unless specifically approved and certified by the engineer.
- Scaffold hoists with obvious faults such as cracked and damaged parts, missing or loose fasteners, lack of manufacturer’s plates and inspection tags (both structural and electrical inspections), and damaged controls cannot be used.
- Personal fall arrest equipment that fails the inspection criteria specified in the relevant part of AS/NZS 1891, Industrial fall-arrest systems and devices is not to be used. Examples of unacceptable equipment include torn or cut webbing, missing manufacturer’s tags, oil soaked harnesses, missing connectors, etc.

6. Clearly understand the role of the verification process and that the competent person is not authorised to permit a variation to the engineer’s instructions.

<b>Competent person statement</b>	
I meet all the aforementioned requirements of the benchmarks for a competent person to perform swing-stage verification set-up (other than for initial set-up).	
Competent person name:	Competent person signature and date:
Phone number:	

<b>PCBU* statement</b>	
I verify that the aforementioned competent person meets all the requirements of the benchmarks for a competent person to perform swing-stage verification set-up (other than for initial set-up).	
PCBU name:	PCBU signature and date:
Phone number:	

\* If the competent person is a contractor, this statement should be signed by the person who engages them.

# Swing-stage suspension system verification statement

**Note:** The suspension system and cradle is to be inspected by an engineer at the time of the initial set-up on site. This verification is for the **re-location of the system and only applies to the suspension rig and ropes**. A new verification statement and checklist must be completed for each installation.

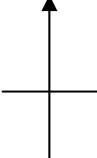
Swing-stage supplier:	Phone number:
Swing-stage installer:	Phone number:
Site address:	
Swing-stage identification no. (if more than one swing-stage on site):	
<b>Competent person verification statement</b>	
<ul style="list-style-type: none"> <li>I meet all the requirements of the benchmarks for a competent person to perform swing-stage verification set-up (other than for initial set-up), as set out in <i>Competent person benchmarks for swing-stage set-up verification</i>.</li> <li>I have inspected the swing-stage suspension system detailed above, completed the accompanying safety checklist and witnessed the load test.</li> <li>The swing-stage suspension system, including the suspension rig and wire ropes, complies with the engineer's specifications detailed in drawing number _____ dated _____ and certified by _____ (engineer's name).</li> </ul>	
Competent person name:	Competent person signature and date:
Phone number:	
<div style="text-align: right; margin-bottom: 20px;">  </div> <p>Plan diagram showing swing-stage location</p>	

<b>Swing-stage suspension system verification checklist</b>		
<b>Item</b>	<b>Inspection result</b> (Tick for pass, cross for fail)	
	<b>First check</b> Date:	<b>Second check</b> (if required) Date:
NOTE: Any failures should be addressed immediately, and a second check done.		
Length of outboard on needles <b>does not exceed</b> that specified in engineer's drawings		
Length of inboard on needles <b>is the same as</b> that specified in engineer's drawings		
All other dimensions are the same as those shown on engineer's drawing		
All connections are the same as those shown on engineer's drawing		
Components are undamaged – no bends, dents, rust (other than minor surface rust)		
Welds are undamaged – no cracks		
No mixing of scaffold components (i.e. are all scaffolding components from the same manufacturer?)		
Suspension rig and needles are made from the same material unless specifically approved by engineer (i.e. steel or aluminium, not both)		
Number and position of counterweights is the same as those shown on engineer's drawing		
Counterweights are secured by positive restraint system (i.e. do not rely on friction devices such as couplers)		
Counterweights are secured with lock and key		
All suspension steel wire ropes are in good condition (refer <i>AS 2759</i> - check strands, wires, kinks, etc)		
Engineer's certification letter to verify supporting structure is adequate, has been sighted and applies to location of unit		
<b>Successful load test undertaken</b>		
Working Load Limit (WLL) of cradle is _____ kg		
<b>Load test options</b> (Refer to <i>Swing-stage load test procedure</i> ): <ul style="list-style-type: none"> <li>• 100 per cent WLL with 100 per cent of load spread evenly across full length of cradle (e.g. cradle WLL 400 kg, evenly distribute 400 kg across the length), or</li> <li>• Each needle tested with 60 per cent of the WLL of the cradle per needle (e.g. cradle WLL is 400 kg, test load is 240 kg applied within one metre of end of cradle).</li> <li>• Use of load cell(s) in accordance with engineer's test procedure.</li> </ul>		
Note: Tests cannot be undertaken in a way that puts testers at risk		
Verifier's signature:	Date:	

# Swing-stage load test procedure

This procedure provides guidance on load testing of swing-stage cradles prior to use – testing is to be carried out prior to the initial use on site and prior to use each time the swing-stage is relocated on that site. This test is in addition to other testing specified in *AS/NZS 4576*, such as testing of the swing-stage hoists to determine the load limiting device is operational (i.e. 25 per cent overload test).

The test is to be witnessed by the person responsible for inspecting the swing-stage suspension system (i.e. the person who completes the *Swing-stage suspension system verification statement*).

## Procedure for testing both needles at one time

Test load size - Test load is to be equivalent to 100 per cent of the working load limit (WLL) with 100 per cent of load spread evenly across full length of cradle (e.g. cradle WLL 400 kg, evenly distribute 400 kg across the length). Note: test weights should be clearly marked with the weight in kilograms.

To test both needles at one time:

1. Ensure suspension system has been inspected and verification statement has been completed (except for load test part and final sign off).
2. Ensure remote control system has been fitted to each swing-stage hoist motor.
3. With cradle located on ground, or landing, load swing-stage cradle with test weights positioned evenly along length of cradle.
4. Standing away from, and to the side of the cradles, operate remote control(s) and raise cradle 1 metre above landing.
5. Hold cradle at 1 metre above landing and check that cradle does not move.
6. Lower cradle to landing and remove test weights.

## Procedure for testing one needle at a time

Test load size - Each needle is to be tested with 60 per cent of the working load limit (WLL) of the cradle per needle (e.g. cradle WLL is 400 kg, test load is 240 kg applied within 1 metre of end of cradle). Note: test weights should be clearly marked with the weight in kilograms. To test one needle at a time:

1. Ensure suspension system has been inspected and verification statement has been completed (except for load test part and final sign-off).
2. Ensure remote control system has been fitted to each swing-stage hoist motor.
3. With cradle located on ground, or landing, load one end of swing-stage cradle with weights positioned within 1 metre of end of cradle.
4. Standing away from, and to the side of the cradles, operate remote control(s) and raise cradle 1 metre above landing.
5. Hold cradle at 1 metre above landing and check that cradle does not move.
6. Lower cradle to landing and move test weights to the opposite end of the cradle, within 1 metre of end of cradle.
7. Repeat steps (4) and (5) above.
8. Lower cradle to ground and remove test weights.

## Test procedure – using load cells

Load cells, anchored between a solid structure and the swing-stage cradle, may be used as an alternative to test weights. When using load cells to undertake the load test, the following conditions are to be met:

1. The test procedure is to be prepared and approved by a professional engineer. A copy of the documentation verifying this is to be located at the test location.
2. The loading is to accurately simulate 100 per cent of the working load limit to the swing-stage suspension system.
3. Application of the test load should not damage the swing-stage cradle in any way and it will likely be necessary to use a load spreading frame between the load cell(s) and swing-stage cradle. If such a frame is used its design is to be certified by the professional engineer.
4. The load cell(s) is to be calibrated at intervals not exceeding one year or at a more regular interval determined by the professional engineer. Calibration documentation is to be available upon request.
5. When using the load cell to carry out the load test, persons operating the swing-stage hoist motors are to stand away from, and to the side of, the cradles.